



Heavy loads
with maximum stability

Profile general overview p. 366

Heavy duty profiles S. 368

Load data p. 372

Connection techniques p. 374

Accessories p. 384

Heavy duty profiles

Heavy duty profile overview



■ Heavy duty profiles sizes

80



D-80x80
p. 368

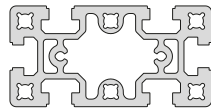

D-80x160
p. 368

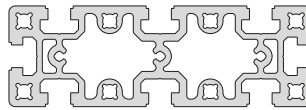

D-80x240
p. 369

160

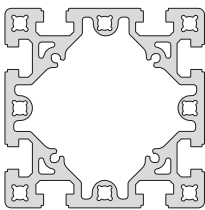

D-160x160
p. 369

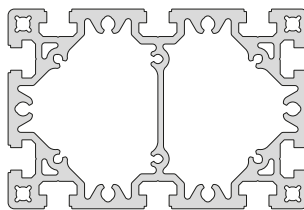

D-160x240
p. 370

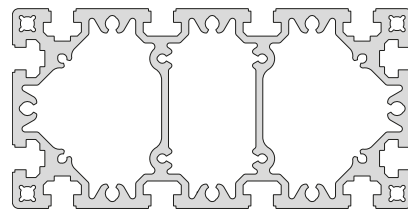

D-160x320
p. 371

Profiles

- Overview p. 366
- Size 80 + 160 p. 368 - 371

Connection techniques

- Press mount connector load data p. 372
- Right-angle connections p. 376
- Cross connections p. 380
- Angle connections p. 382
- Face-to-face and parallel connections p. 383

Accessories

- Slot stones from p. 386
- Profile covers from p. 390
- Feet from p. 392
- Connecting plates from p. 394

Heavy duty profiles / size 80

D-80x80

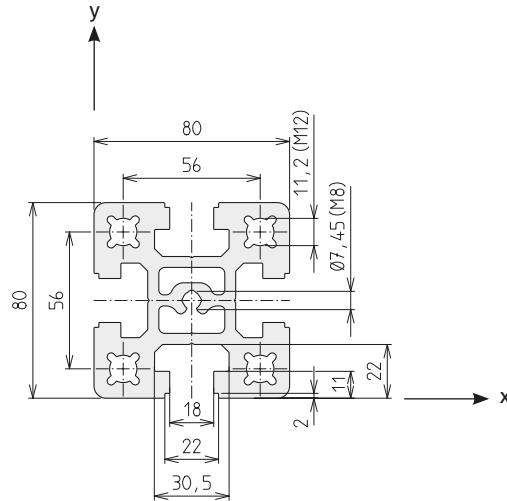
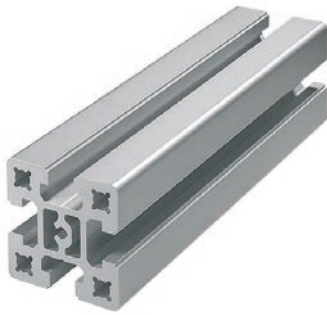



Area	3200	mm ²
I _x	198.0	cm ⁴
I _y	199.3	cm ⁴
W _x	49.6	cm ³
W _y	49.8	cm ³
Weight	8581	g/m

Code No. Profile D-80x80			Anodised	
4C45000	Cut to size	max. 6000 mm	Clear	
4C45001	Bar	6000 mm	Clear	
Connection	Quantity required per conn.	Slot geometry	Press mount connector	Code No. /unit
 Press mount connector long.+transverse	1	D	-N- 80	4C16701

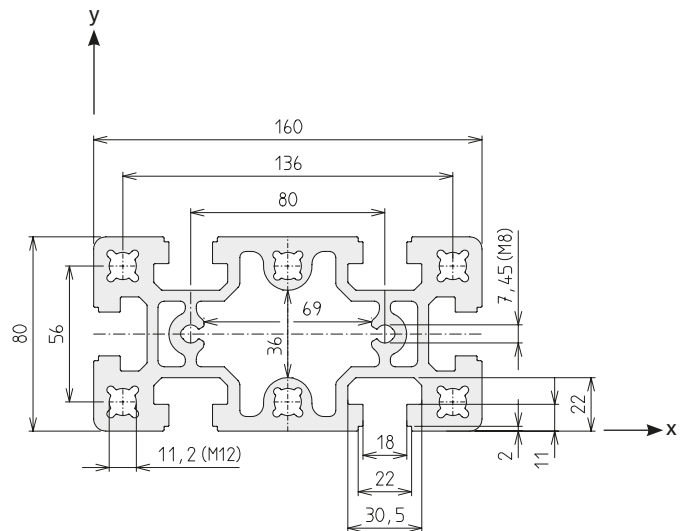
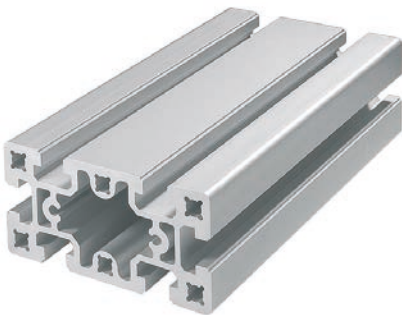
D-80x160

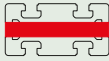

Area	5212	mm ²
I _x	367.5	cm ⁴
I _y	1397.0	cm ⁴
W _x	91.6	cm ³
W _y	174.6	cm ³
Weight	14073	g/m

Code No. Profile D-80x160			Anodised	
4C15000	Cut to size	max. 6000 mm	Clear	
4C15001	Bar	6000 mm	Clear	
Connection	Quantity required per conn.	Slot geometry	Press mount connector	Code No. /unit
 long.	1	D	-N- 160	4C16700
 transverse	2		-N- 80	4C16701

Note: Holes are designed as self-tapping screw channels (M8/M12)



D-80x240

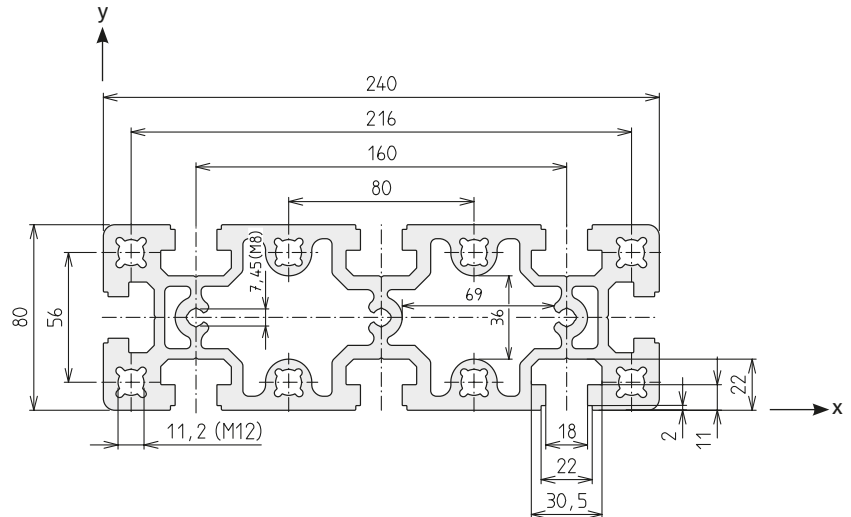
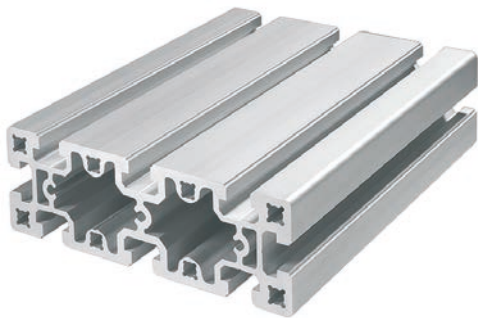

Code No. Profile D-80x240			Anodised
4C55000	Cut to size	max. 6000 mm	Clear
4C55001	Bar	6000 mm	Clear

Area 7422 mm²
 I_x 540.8 cm⁴
 I_y 4268.2 cm⁴
 W_x 135.2 cm³
 W_y 355.7 cm³
 Weight 20015 g/m

Connection	Quantity required per conn.	Slot geometry	Press mount connector	Code No. / unit
long.	1	D	-N- 240	4C56700
transverse	3		-N- 80	4C16701

D-160x160

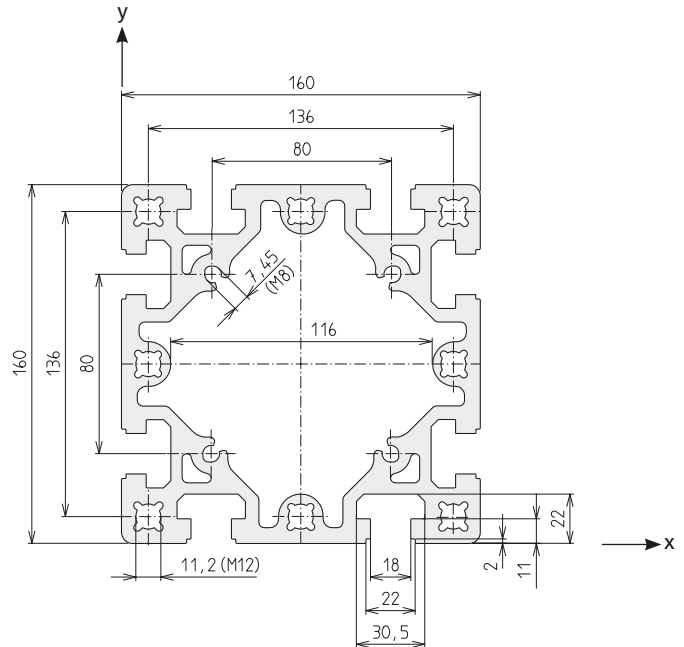
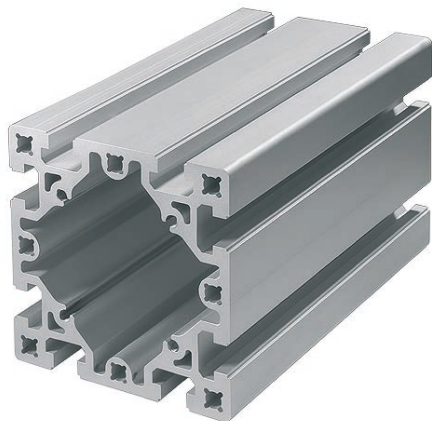

Code No. Profile D-160x160			Anodised
4C25000	Cut to size	max. 6200 mm	Clear
4C25001	Bar	6300 mm	Clear

Area 8131 mm²
 I_x 2493.6 cm⁴
 I_y 2493.6 cm⁴
 W_x 311.7 cm³
 W_y 311.7 cm³
 Weight 21955 g/m

Connection	Quantity required per conn.	Slot geometry	Press mount connector	Code No. / unit
long. +transverse	2	D	-N- 160	4C16700

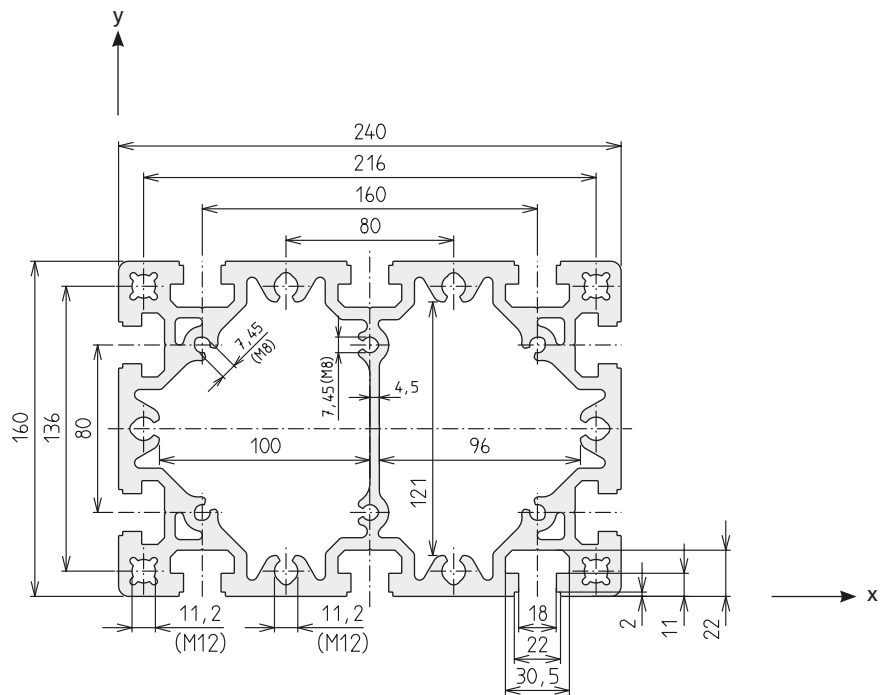
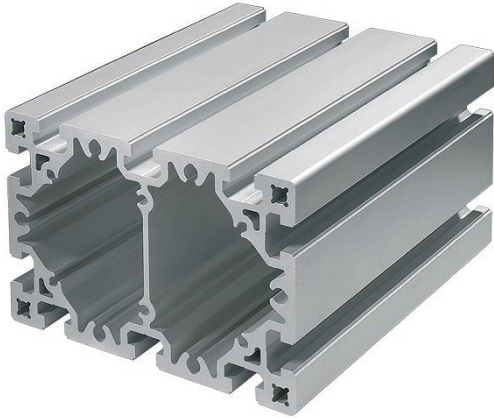

Heavy duty profiles / size 160

D-160x240



Code No. Profile D-160x240			Anodised
4C65000	Cut to size	max. 6000 mm	Clear
4C65001	Bar	6000 mm	Clear

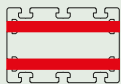

Area	10986	mm ²
I_x	3601.5	cm ⁴
I_y	7333.4	cm ⁴
W_x	450.2	cm ³
W_y	611.1	cm ³
Weight	29647	g/m

Connection	Quantity required per conn.	Slot geometry	Press mount connector	Code No. /unit
 long.	2	D	-N- 240	4C56700
 transverse	3		-N- 160	4C16700

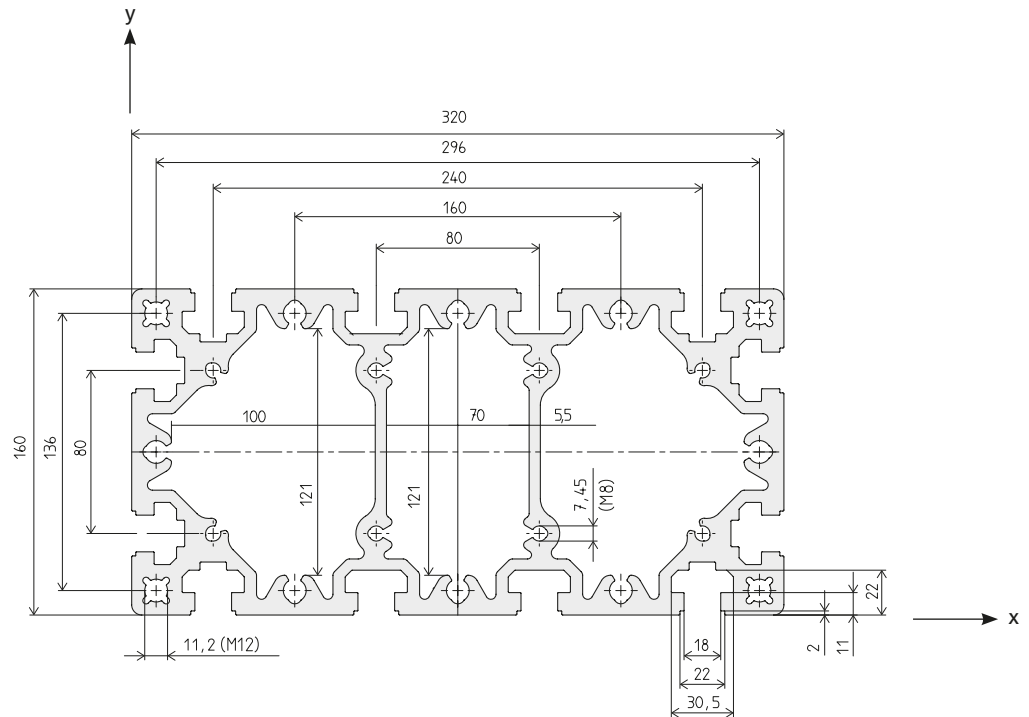
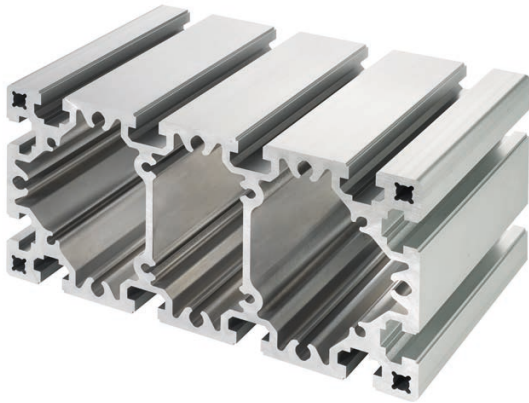
D-160x320

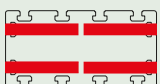

Code No. Profile D-160x320			Anodised
4C35000	Cut to size	max. 6200 mm	Clear
4C35001	Bar	6300 mm	Clear

Connection	Quantity required per conn.	Slot geometry	Press mount connector	Code No. /unit
 long.	4	D	-N- 160/320	4C36700
 transverse	4		-N- 160	4C16700

Area	13671	mm ²
I_x	4656.0	cm ⁴
I_y	15618.3	cm ⁴
W_x	582.0	cm ³
W_y	976.1	cm ³
Weight	36912	g/m

Note: Holes are designed as self-tapping screw channels (M8/M12)

Load data

D-profiles with press mount connector -static-



Press mount connector -N-



Press mount connector -R-

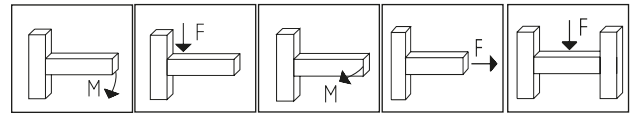

Press mount connectors included	Version	Profile	Weight	M [Nm]	F [N]	M [Nm]	F [N]	F [N]	
1x	Press mount connector Type -N-	80x80	0.30 kg	560	2,900	560	11,000	4,300	
1x		80x160 (long.)	0.52 kg	1,700	7,500	1,120	28,000	11,000	
2x		80x160 (trans.)	0.60 kg	1,700	10,000	1,120	28,000	15,000	
1x		80x240 (long.)	0.73 kg	2,800	6,000	1,120	28,000	9,000	
3x		80x240 (trans.)	0.90 kg	3,000	8,600	1,680	33,000	12,900	
2x		160x160	1.04 kg	3,200	15,000	3,200	56,000	22,000	
2x		160x240 (long.)	1.46 kg	5,600	12,000	5,000	56,000	18,000	
3x		160x240 (trans.)	1.56 kg	5,800	18,000	5,200	79,000	27,000	
4x		160x320 (long.)	2.08 kg	7,800	18,000	4,000	62,000	36,000	
4x		160x320 (trans.)	2.08 kg	8,000	28,000	6,500	98,000	42,000	
1x		Press mount connector Type -R-	80x80	0.25 kg	560	2,900	560	11,000	4,300
1x			80x160 (long.)	0.48 kg	1,700	7,500	1,120	28,000	11,000
2x	80x160 (trans.)		0.50 kg	1,700	10,000	1,120	28,000	15,000	
1x	80x240 (long.)		0.69 kg	2,800	6,000	1,120	28,000	9,000	
3x	80x240 (trans.)		0.75 kg	3,000	8,600	1,680	33,000	12,900	
2x	160x160		0.96 kg	3,200	15,000	3,200	56,000	22,000	
2x	160x240 (long.)		1.38 kg	5,600	12,000	5,000	56,000	18,000	
3x	160x240 (trans.)		1.44 kg	5,800	18,000	5,200	79,000	27,000	
4x	160x320 (long.)		1.92 kg	7,800	18,000	4,000	62,000	36,000	
4x	160x320 (trans.)		1.92 kg	8,000	28,000	6,500	98,000	42,000	

Connection techniques

Versions

Right-angle connections

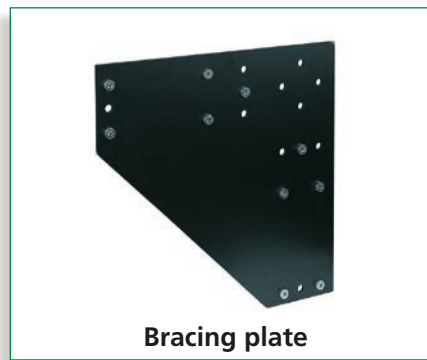
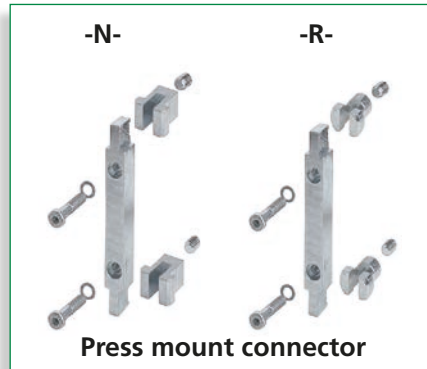

Cross connections



Angle connections

Face-to-face and parallel connections



Table of contents

Connection techniques

Right-angle connections

- Press mount connector from p. 376
- Angle bracket..... from p. 378
- Bracing plate from p. 379
- Corner connecting plate from p. 379

Cross connections

- Keyed clamp connector -Q- from p. 380

Angle connections

- Frame joint from p. 382

Face-to-face and parallel connections

- Keyed clamp connector -P- from p. 383
- Connecting plate..... from p. 383

Right-angle connections

Press mount connector

- Simple, cost-effective and high-strength profile connection
- No profile machining necessary
- Can be disconnected at any time and reused
- Minimal effort required in construction

Material: Galvanised steel

Includes:

The Order No. includes one press mount connector. Depending on the orientation of the connection (longitudinal or transverse), the appropriate number of press mount connectors must be ordered. Please note the information and the connection pictograms in the profile data on page 368– 371.

Type -N-



Code No.	Type	Weight	For profile (quantity required per connection)
4C16701	-N-80	0.30 kg	80x80 (1x), 80x160 (2x), 80x240 (3x)
4C16700	-N-160	0.52 kg	80x160 (1x), 160x160 (2x), 160x240 (3x), 160x320 (4x)
4C36700	-N-160/320	0.52 kg	160x320 (4x)
4C56700	-N-240	0.73 kg	80x240 (1x), 160x240 (2x)

Type -R-



Code No.	Type	Weight	For profile (quantity required per connection)
4C16711	-R-80	0.25 kg	80x80 (1x), 80x160 (2x), 80x240 (3x)
4C16710	-R-160	0.48 kg	80x160 (1x), 160x160 (2x), 160x240 (3x), 160x320 (4x)
4C36710	-R-160/320	0.48 kg	160x320 (4x)
4C56710	-R-240	0.69 kg	80x240 (1x), 160x240 (2x)

Assembly steps (press mount connector -N-)

1. Screw set screw M10 (2) into thrust compression piece -N- (1)
2. Place the thrust compression piece -N- (1) into the profile for the connection strip (3) as an assembly aid
3. Align the connection strip (3) and fix it in the screw channel with M8 socket head cap screws (4). It is recommended to create the thread with a thread forming tap. Tighten it just until the connector is fixed, max. 5 Nm. However, oiled screws can be screwed directly into the profile.
4. Remove the thrust compression pieces (5) and push them into the slot(s) of the profile to be fixed*
5. Insert the profile with the connection strips (6) into the profile with the thrust compression pieces (7)
6. Push the thrust compression pieces (8) into the connection strip
7. Tighten the set screws M10 (2) to 25 Nm (Type -N- and -R- 80 to 12 Nm)

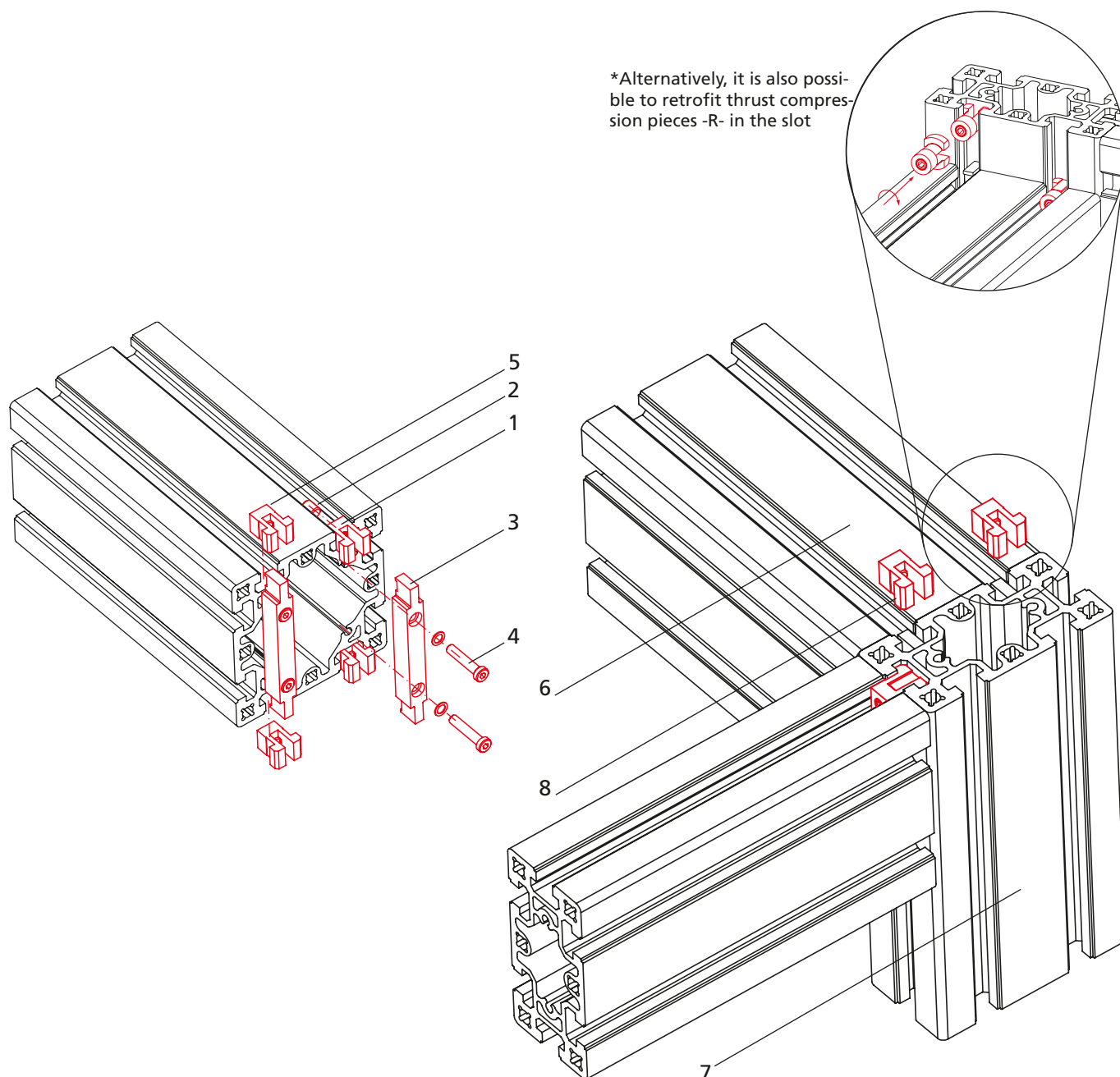

Right-angle connections

Angle bracket

Material: Gravity die-cast aluminium,
Angle tolerance: $\pm 5^\circ$



Application examples

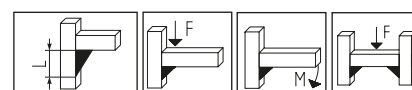
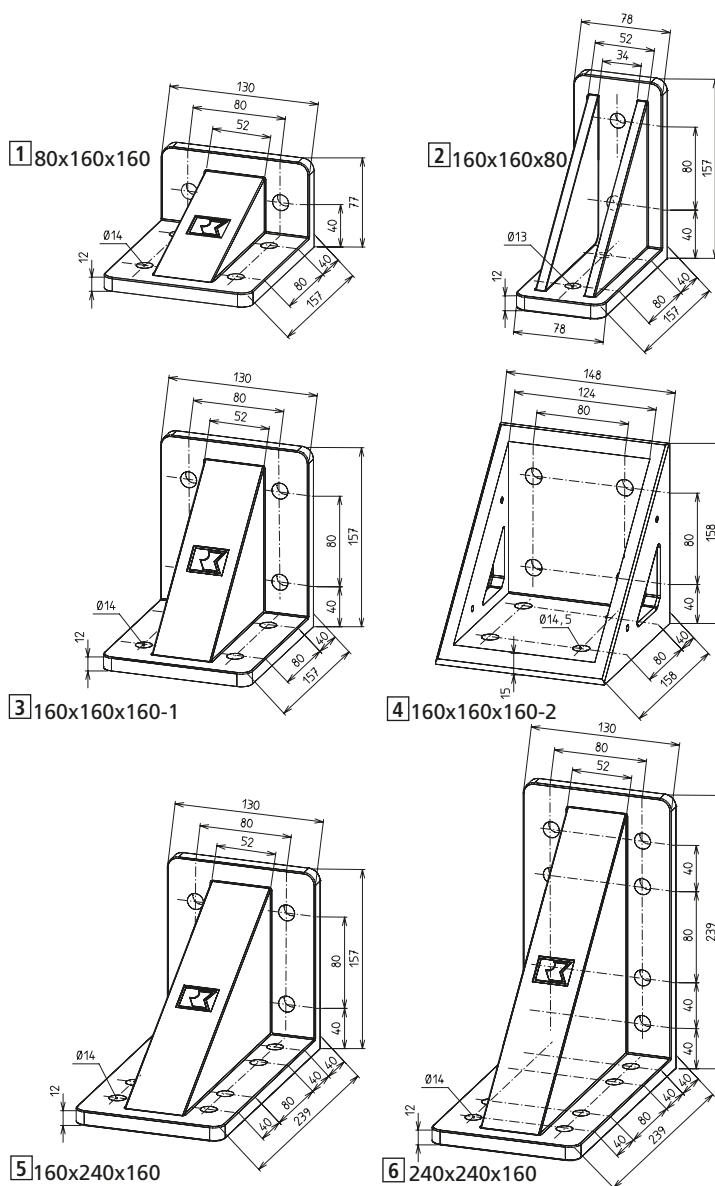
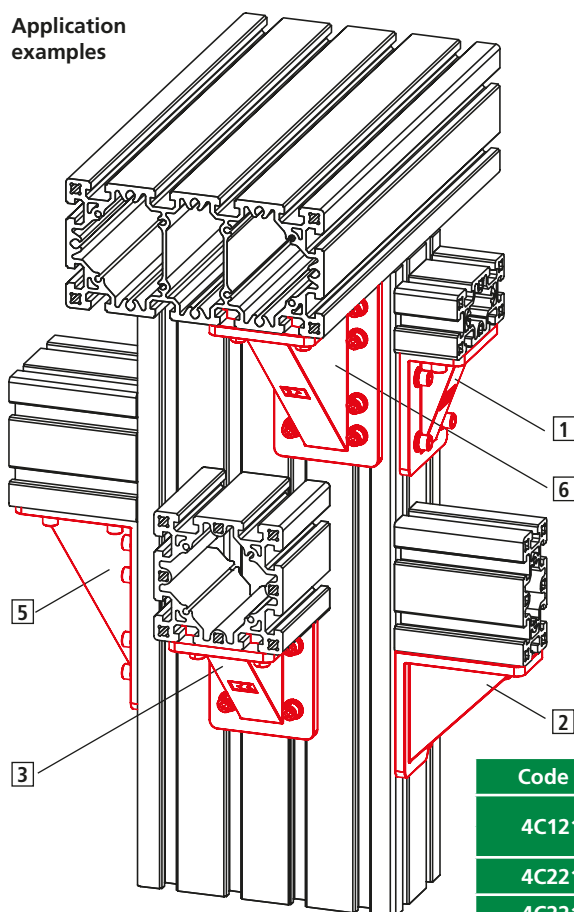

Code No.	Type	Weight	L [mm]	F [N]	M [Nm]	F [N]
4C12100	80x160x160	1.0 kg	80	11,000	810	30,000
			160	26,200	810	55,000
4C22100	160x160x80	1.2 kg	160	13,100	1,500	29,000
4C22101	160x160x160-1	1.5 kg	160	22,000	3,100	58,000
4C22102	160x160x160-2	2.1 kg	160	22,000	2,500	36,000
4C22103	160x240x160	2.1 kg	160	24,000	2,700	53,000
			240	35,000	2,800	75,000
4C22104	240x240x160	2.8 kg	240	40,300	6,200	75,000

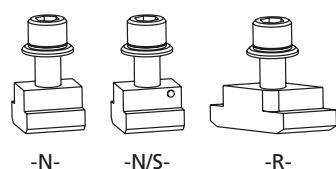

Fixing sets for angle bracket (one screw with slot stone and washer)

Code No.	Type	Weight
4C16200	M12x30, slot stone -N-	0.14 kg
4C16201	M12x30, slot stone -N/S-	0.14 kg
4C16202	M12x30, slot stone -R-	0.13 kg

Bracing plate

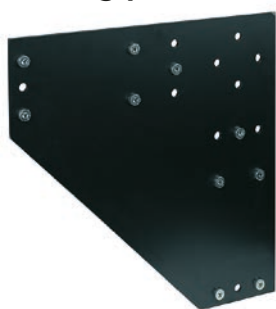

- The bracing plates are for the superficial bracing of a profile connection.

Material: Black powder-coated steel

Includes: Complete with fastenings

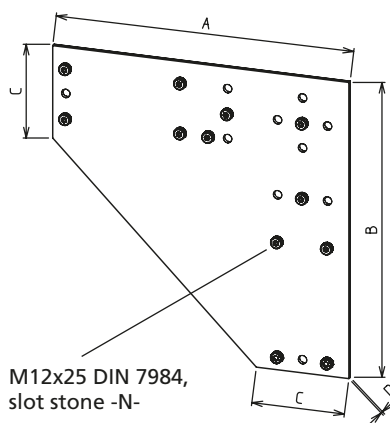
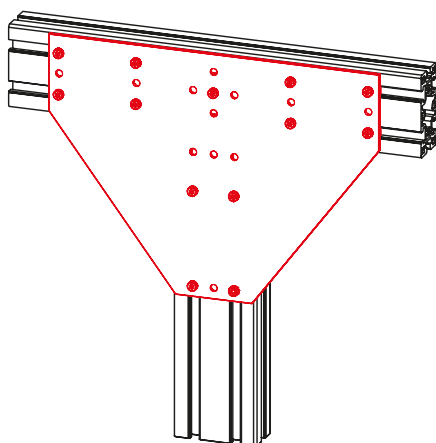

M12x25 DIN 7984, slot stone -N-

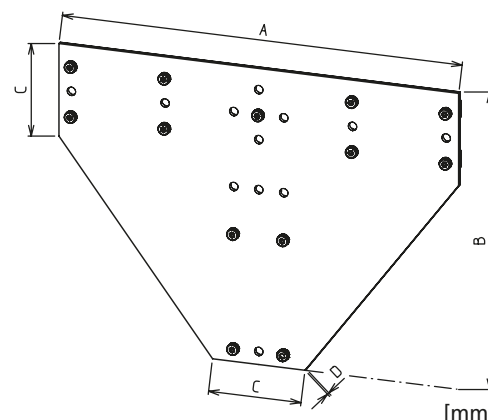

[mm]

Code No.	Type	A	B	C	D	Weight
4C12110	-L-	474	474	148	6	9.3 kg
4C12111	-T-	640	474	148	6	12.0 kg

Corner connecting plate



- The corner connecting plate is for supporting the press mount connectors (e.g. relieving high tensile loads).

Material: Black powder-coated steel

Includes: Complete with fastenings

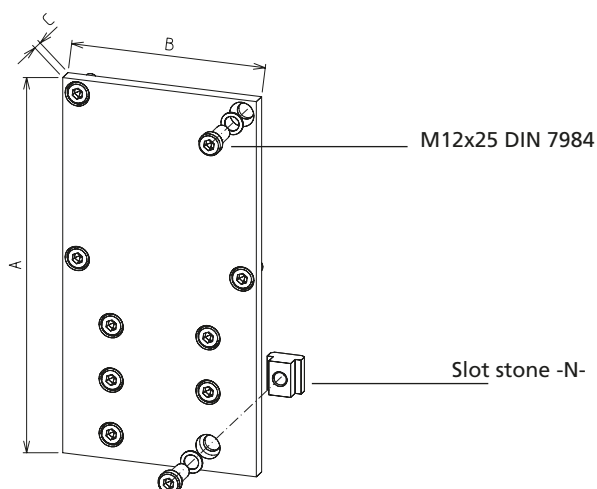
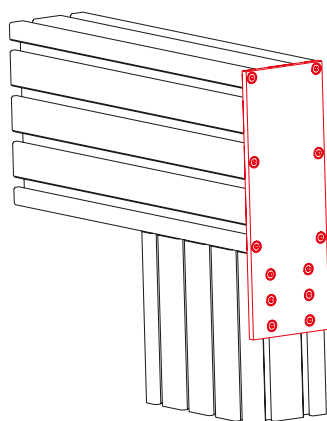

M12x25 DIN 7984

Slot stone -N-

[mm]

Code No.	Type	A	B	C	Weight
4C22400	160x160	310	160	12	5.3 kg
4C22401	160x320	470	160	12	7.7 kg

Cross connections

Keyed clamp connector -Q-



- Simple realisation of cross connections
- No profile machining necessary

Material: Galvanised steel

Includes:

Complete fixing set for one connection

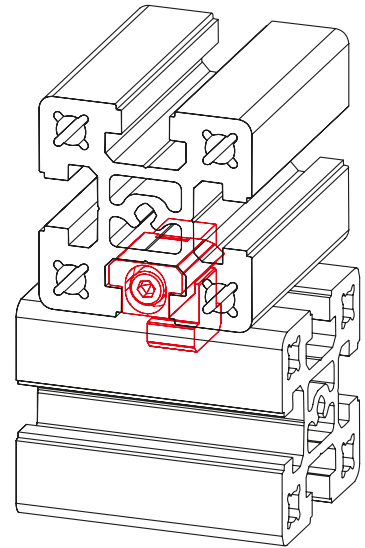

[mm]

Code No.	Type	Weight
4C16501	Keyed clamp connector -Q-	0.22 kg

Angle connections

Frame joint

- For supporting a structure at a 45° angle under high loads

Material: Black powder-coated gravity die-cast aluminium
Includes: One complete frame joint with fastenings
 2 cover plates with fastenings available as an accessory

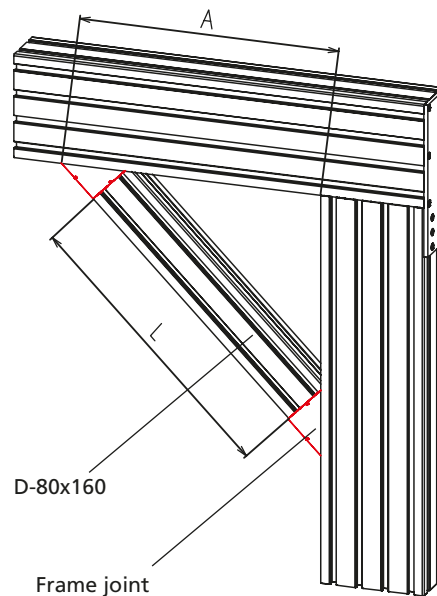
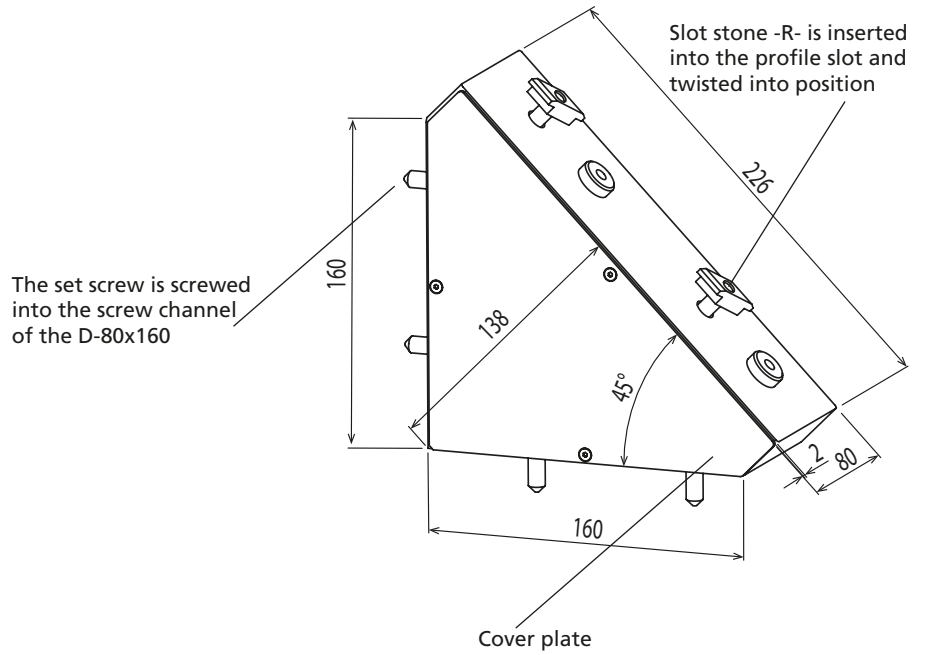

Cut to size

D-80x160:

$$L = (A : 0.707) - 355$$

[mm]

Code No.	Type	Weight
4C12105	Frame joint 45°	1.8 kg
4C12106	Two cover plates	0.6 kg

Face-to-face and parallel connections

Keyed clamp connector -P-

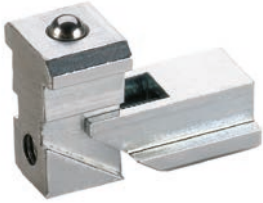

- For parallel flange mounting of profiles
- No profile machining necessary

Material:
Galvanised steel
Includes:
Complete fixing set for one connection

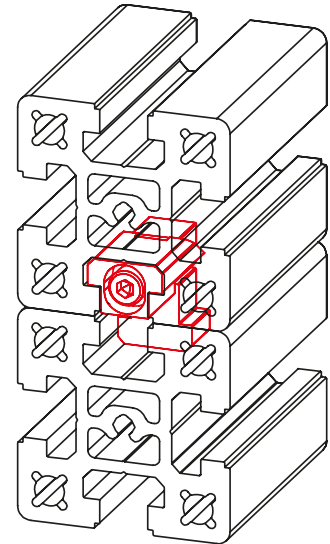

[mm]

Code No.	Type	Weight
4C16502	Keyed clamp connector -P-	0.22 kg

Connecting plate



- For the flange connection of profile ends
- For extending profiles and extending existing structures

Material:
Galvanised steel
Includes:
Complete fixing set for one connection

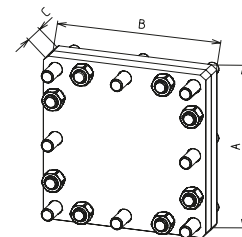
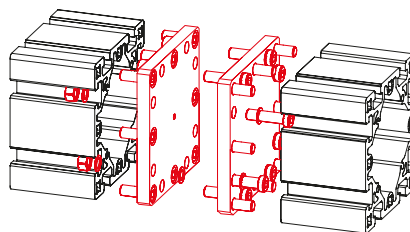

[mm]

Code No.	Type	A	B	C	Weight
4C46410	80x80	80	160	30	1.7 kg
4C16410	80x160	80	160	30	3.3 kg
4C56410	80x240	80	240	30	4.9 kg

[mm]

Code No.	Type	A	B	C	Weight
4C16411	160x160	160	160	30	6.5 kg
4C66410	160x240	160	240	40	14.3 kg
4C16412	160x320	160	320	40	16.6 kg

Accessories

Versions



Adapter slot stone



Slot stone -N-



Slot stone -N/S-



Slot stone -N/L-

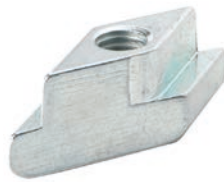

Slot stone -R-



Slot stone -VF-



Slot stone -RF-



Cover plate



Cover profile



Levelling foot



Levelling foot with fixing bracket



Connecting plate for feet



Base plate

Table of contents

Accessories	
Slot stones	<ul style="list-style-type: none"> ■ Adapter slot stone p. 386 ■ Slot stone -N- p. 386 ■ Slot stone -N/S- p. 387 ■ Slot stone -N/L- p. 387 ■ Slot stone -R- p. 388 ■ Slot stone -VF- p. 388 ■ Slot stone -RF- p. 389
Profile covers	<ul style="list-style-type: none"> ■ Cover plate p. 390 ■ Cover profile..... p. 390
Feet	<ul style="list-style-type: none"> ■ Levelling foot p. 392 ■ Levelling foot with fixing bracket p. 393
Connecting plates	<ul style="list-style-type: none"> ■ Connecting plate for feet..... p. 394 ■ Base plate p. 395

Slot stones

Adapter slot stone



- For connecting the elements of the profile assembly system with the 10 mm-wide slot to the D-profiles with the 18 mm-wide slot.

Material: Galvanised steel
Includes:
 1 adapter slot stone

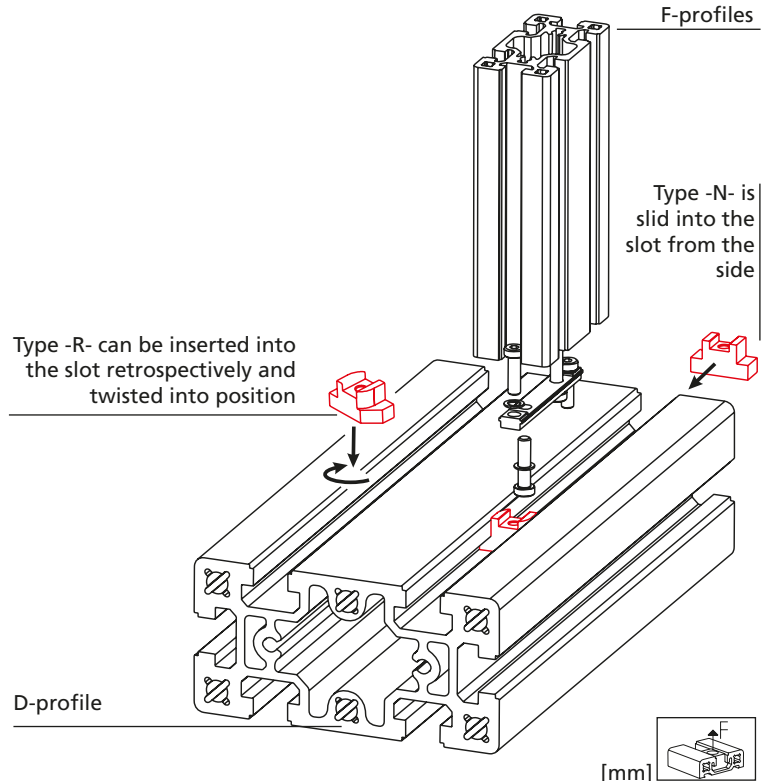

*Slot 18 mm = D-profiles
 Slot 10 mm = F-profiles

Code No.	Type	Version	F [N]
4C12201	-N-	Slot 18 to 10 mm*	10,000
4C12202	-R-	Slot 18 to 10 mm*	9,000

Slot stone -N- (similar to DIN 508)



- For fixing accessories to a profile.
- This slot stone should be slid into place before assembly.

Material: Galvanised steel
 Strength class 8

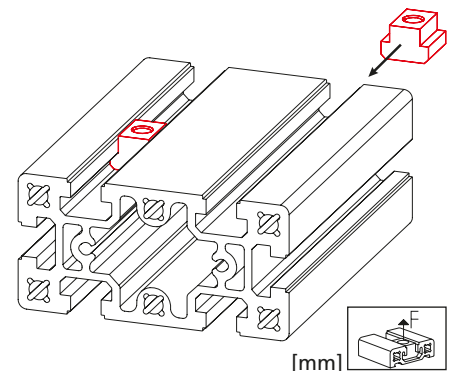
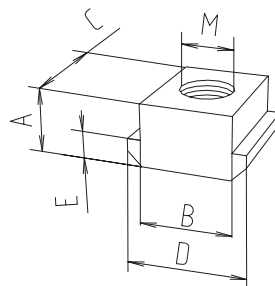

Code No.	Type	A	B -0.3/-0.6	C	D	E	M	Weight	F [N]
4C12203	M8	18.5	18	28	28	10	M8	0.1 kg	20,000
4C12204	M10	18.5	18	28	28	10	M10	0.1 kg	25,000
4C12205	M12	18.5	18	28	28	10	M12	0.1 kg	35,000

**Slot stone -N/S-
(similar to DIN 508)**

- Same geometry and function as slot stone -N-
- A spring clip prevents the slot stone from slipping
- For easier attachment mounting

Material: Galvanised steel
Strength class 8

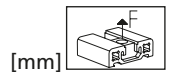
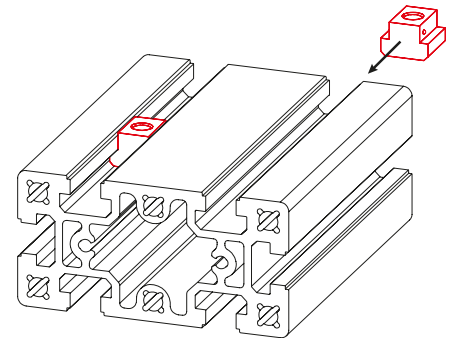
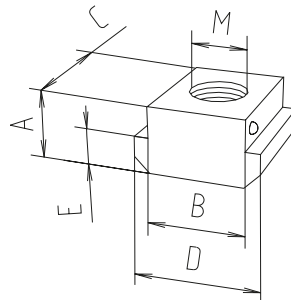

Code No.	Type	A	B -0.3/-0.6	C	D	E	M	Weight	F [N]
4C12206	M8	18.5	18	28	28	10	M8	0.1 kg	20,000
4C12207	M10	18.5	18	28	28	10	M10	0.1 kg	25,000
4C12208	M12	18.5	18	28	28	10	M12	0.1 kg	35,000

**Slot stone -N/L-
(similar to DIN 508)**

- Same geometry and function as slot stone -N-
- Higher perm. force due to the longer version

Material: Galvanised steel
Strength class 8

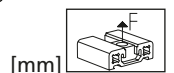
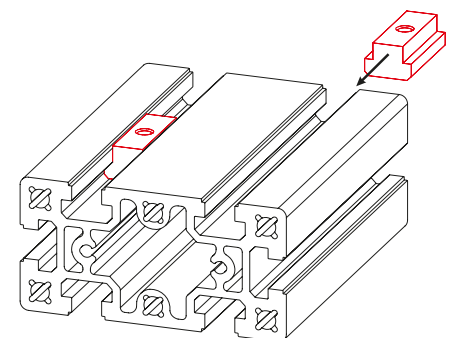
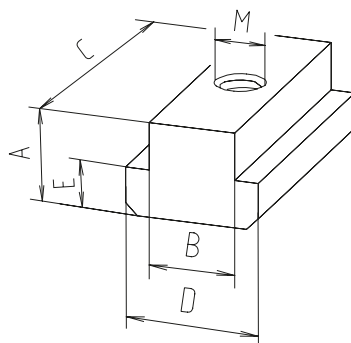

Code No.	Type	A	B -0.3/-0.6	C	D	E	M	Weight	F [N]
4C12209	M10	18.5	18	56	28	10	M10	0.2 kg	25,000
4C12210	M12	18.5	18	56	28	10	M12	0.2 kg	35,000

Slot stones

Stone stone -R-

- The slot stone is inserted anywhere in the profile slot
- The action of tightening the slot stone turns it into its final clamping position

Material: Galvanised steel
Strength class 8

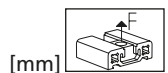
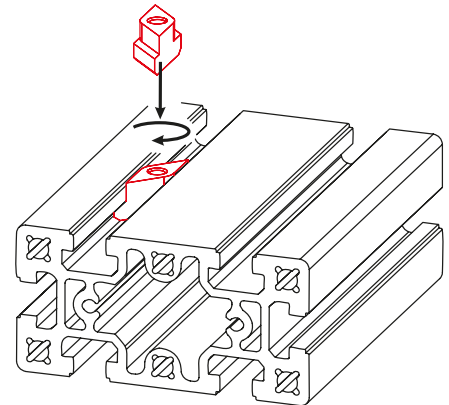
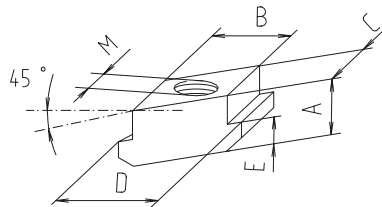

Code No.	Type	A	B -0.3/-0.6	C	D	E	M	Weight	F [N]
4C12211	M8	18.5	18	18	28	10	M8	0.1 kg	20,000
4C12212	M10	18.5	18	18	28	10	M10	0.1 kg	25,000
4C12213	M12	18.5	18	18	28	10	M12	0.1 kg	35,000

Slot stone -VF-

- For fixing attachments under low loads
- Slid into the profile slot from the side

Material: Galvanised steel

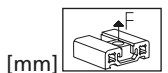
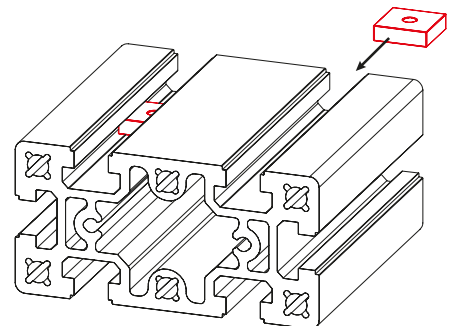
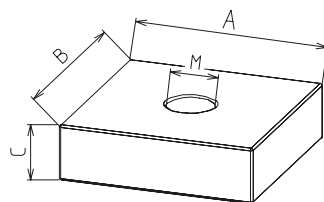
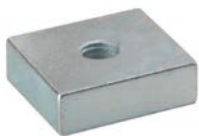

Code No.	Type	A	B	C	M	Weight
4C16204	M6	28	28	8	M6	0.05 kg
4C16203	M8	28	28	8	M8	0.04 kg



Slot stone -RF-

- For fixing attachments under low loads
- The slot stone is inserted anywhere in the profile slot
- The action of tightening the slot stone turns it into its final clamping position

Material: Galvanised steel

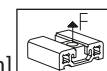
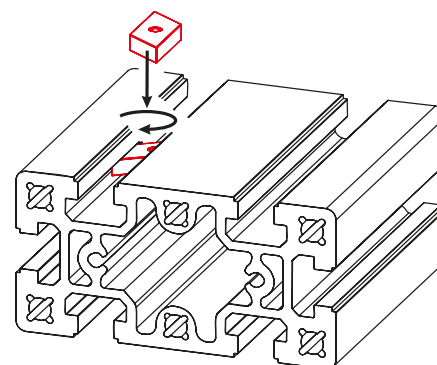
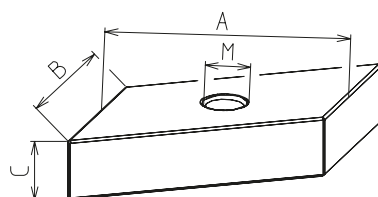

[mm]

Code No.	Type	A	B	C	M	Weight
4C16205	M6	28	18	8	M6	0.04 kg
4C16206	M8	28	18	8	M8	0.04 kg

Profile covers

Cover plates

- For covering the profile ends
- Fixed with socket head button screws

Material: Black powder-coated galvanised steel

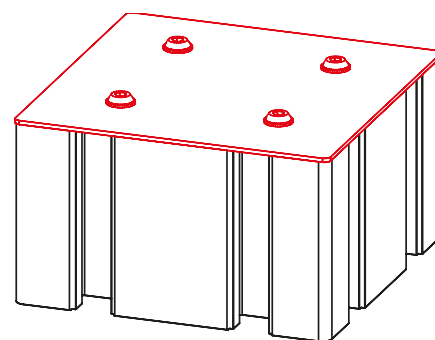
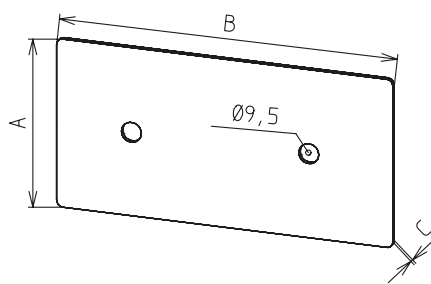

Code No.	Type	A	B	C	Weight
4C42410	80x80	80	80	2	0.1 kg
4C12410	80x160	80	160	2	0.2 kg
4C52410	80x240	80	240	2	0.3 kg
4C22410	160x160	160	160	2	0.4 kg
4C62410	160x240	160	240	2	0.6 kg
4C32410	160x320	160	320	2	0.8 kg

[mm]

Cover profile

- For the flush covering of longitudinal slots.
- Provides protection against soiling
- For fixing cables routed in the slots

Material: Black plastic



Code No.	Type
4C10501	2 m bar

Feet

Order instruction:

- Purchase only in lot sizes and amultiple of that see product table below

- The levelling feet are available in different versions.

Material:
Black plastic foot, galvanised spindle

Levelling foot

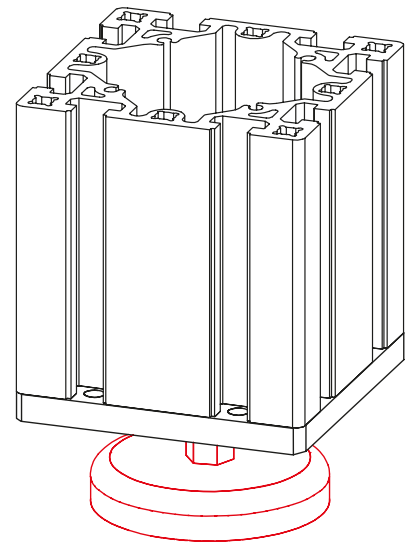
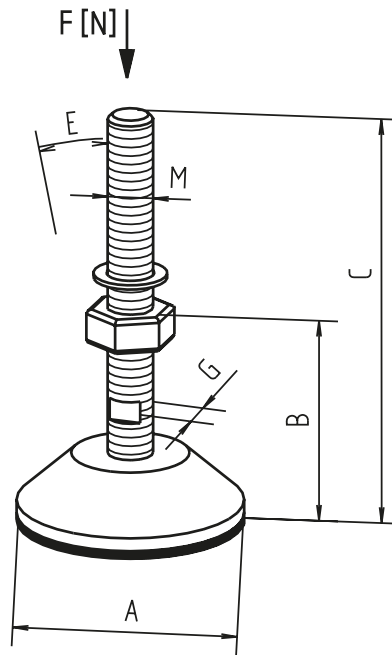

*With vibration absorber

**With this version, 2 fixing holes can be punched through

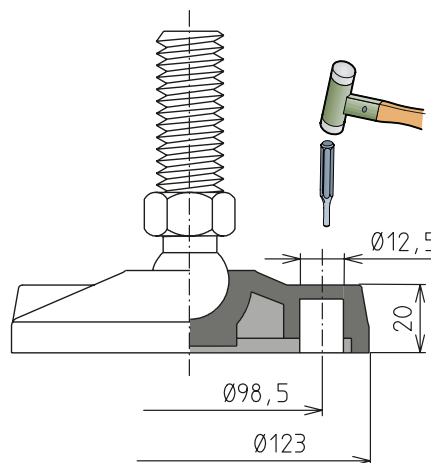

Code No.	Type	lot sizes	A	B	C	M	E	G	Weight	F [N]
4016301	M8	-	47	15	40	M8	15°	-	0.03	1,500
4016303	M12	-	80	24	117	M12	15°	12	0.14	7,000
4046312	M20*	-	123	70	215	M20	15°	16	0.70	10,000
4696302	M20	-	123	61	207	M20	15°	16	0.60	20,000
Foot with fixing hole** (see diagram)										
4C16300	M20	-	123	70	155	M20	8°	22	0.60	45,000
	Fixing bolt 8x60	4, 8, 12... pcs								

Levelling foot with fixing bracket

- This fixing bracket can be used if it is necessary for structural reasons to attach a foot to the side of the profile.

Material: Gravity die-cast aluminium angle bracket,
fastenings: Galvanised spindle
Includes:
 One fixing bracket with levelling foot and fastenings

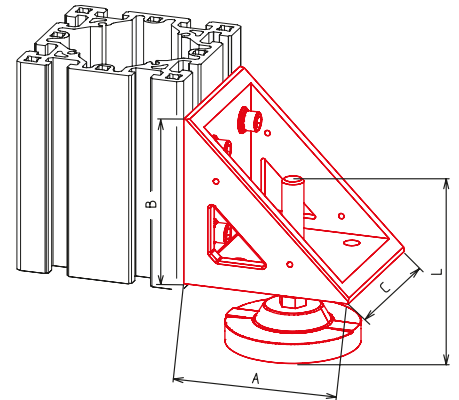
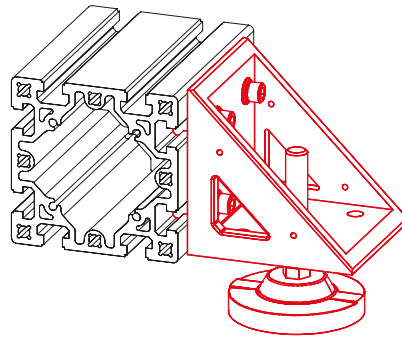

Code No.	Type	A	B	C	L	Weight
4C22105	M20	158	158	148	155	3.3 kg

Connecting plates

Connecting plate for feet

- Connecting plate with tapped hole for feet
- Also suitable for taking eye bolts.
- As of type 160x240 the plate has 2 tapped holes.

Material:
Galvanised steel

Includes:
Connecting plate with complete fixing set for connection to one profile
*Profile 80x80 has a screw channel of $\text{Ø}7.45$ (M8). If using a connecting plate/foot M12, a hole must be drilled in this channel. The drill listed below should ideally be used.

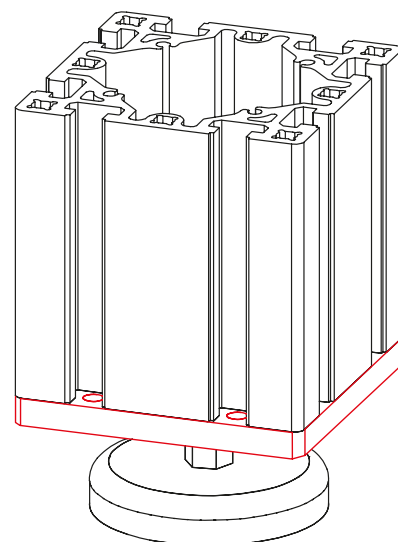
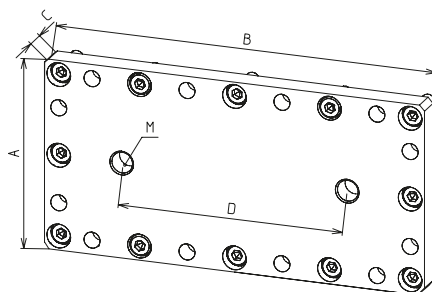

Adjustment range 0-28 mm
Max. compressive force 20 KN

Code No.	Type	A	B	C	D	M	Weight
4C46405	80x80*	80	80	15	0	12	0.7 kg
4C16405	80x160	80	160	15	0	20	1.4 kg
4C56405	80x240	80	240	15	130	12	2.2 kg
4C26405	160x160	160	160	15	0	20	2.9 kg
4C66405	160x240	160	240	20	130	20	5.8 kg
4C36405	160x320	160	320	20	190	20	7.7 kg
4006652	Drilling fixture for profile D-80x80 / foot M12						

Base plate

- For taking high supporting forces
- The four levelling feet help to align a structure exactly
- If necessary, the feet can be screwed to the floor

Material: Black powder-coated galvanised steel base plate, reinforced black polyamide foot, galvanised spindle, galvanised fastenings

Includes: Complete base plate with four levelling feet and fastenings for the connection of one profile



Fig. 1

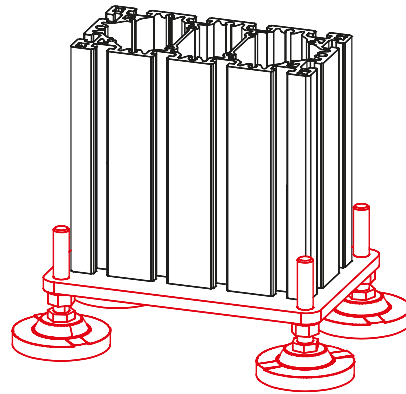
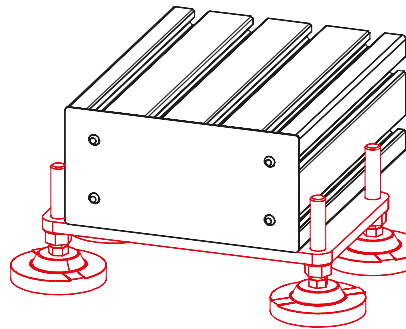

Fig. 2



Base plate with slot stones for the cross connection of one profile 160x320

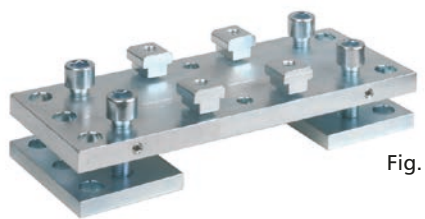
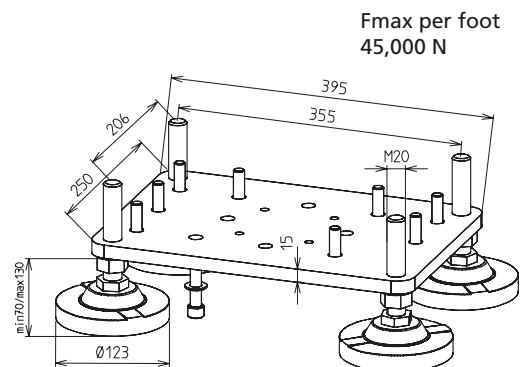
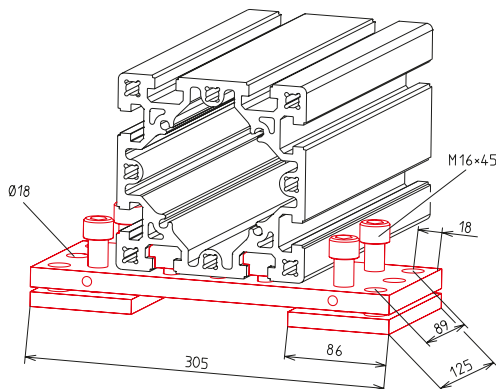

Fig. 3



Code No.	For profile	Weight	Fig.
4C26406	160x160	13.3 kg	1
4C36408	160x240	13.6 kg	1
4C36406	160x320	13.7 kg	1
4C36407	160x320 with slot stones	14.7 kg	2
4C26407	160, adjustable	8.2 kg	3