



RK ROSE+KRIEGER

Support arm / equipment carrier system

RK Monitor Mounting page 254

GT 48 page 264

GT 50, 60, 80 page 274

Support arm / equipment carrier system

RK Monitor Mounting

All purpose mounting for monitors, touch panels and operating units

This mounting for monitors, touch panels and other operating units is flexible, offers many degrees of freedom and thus can be used universally. Due to compability to RK Connecting Technology as well to the RK Profile System most different connections are realizable.

Ideal range of applications:

- ✓ General industrial applications
- ✓ Plants and machines
- ✓ Control centers
- ✓ Ergonomic work stations

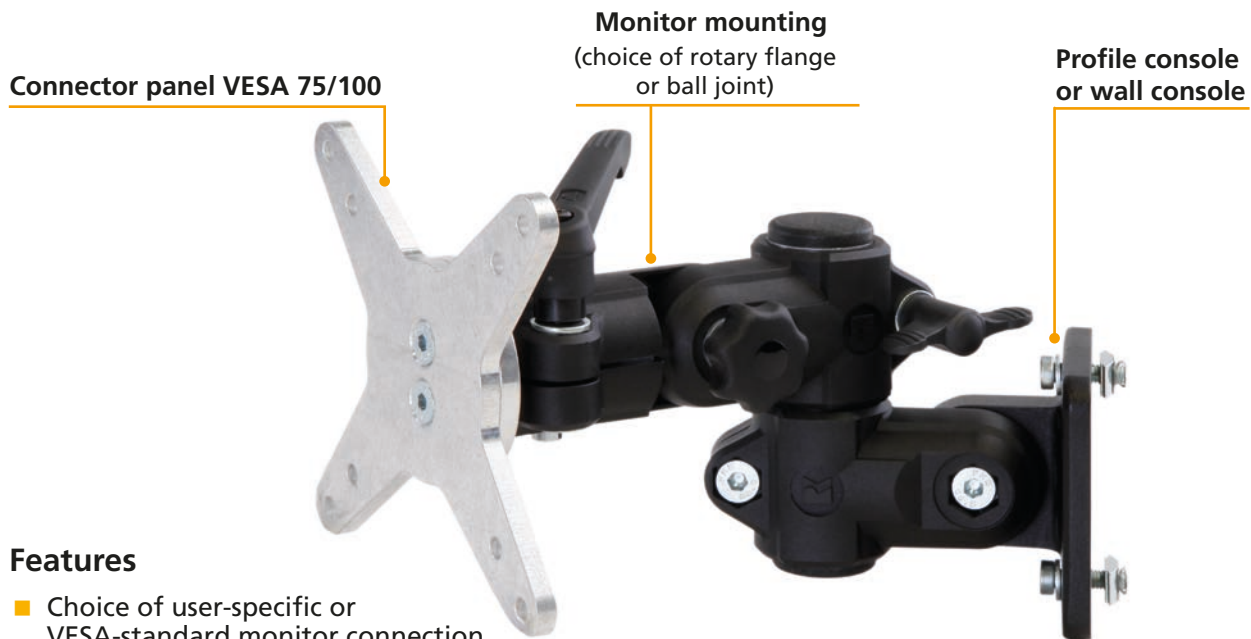

Features

- Choice of user-specific or VESA-standard monitor connection
- High-strength materials guarantee a long-term load-bearing capacity of up to 25 kg, for reliable processes
- Highly ergonomic thanks to personalised height adjustment
- Optimum adjustment of the field of vision thanks to side-turning
- Vibration-proof locking in 15° increments
- Connects to aluminium profile, and thus also to the machine frame using slot stones
- Universal mounting holes facilitate simple wall mounting

Rotary flange monitor mounting

- Max. load capacity 25 kg (static)
- Can be turned through 90°



Ball joint monitor mounting

- Max. load capacity 10 kg (static)
- 60° free swivelling





Rotary flange monitor mounting



Locking in 15° - steps

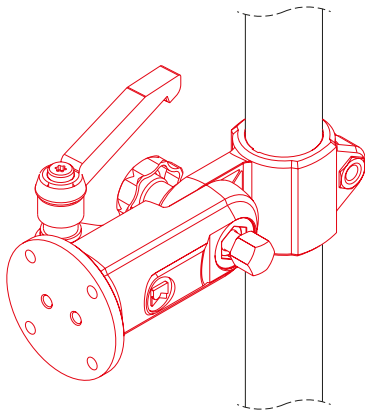
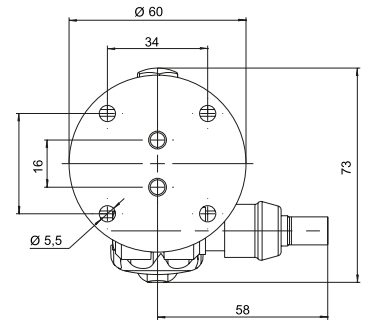
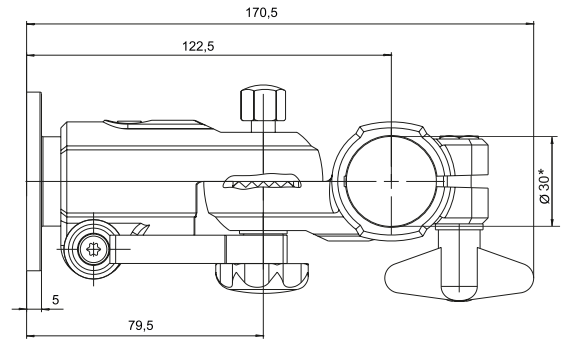

90°

Code No.	Weight	max. load
193000030C11	370 g	25 kg

*Other cross-sections by reducing bushes (see page 6)

Ball joint monitor mounting



Locking in 15° - steps

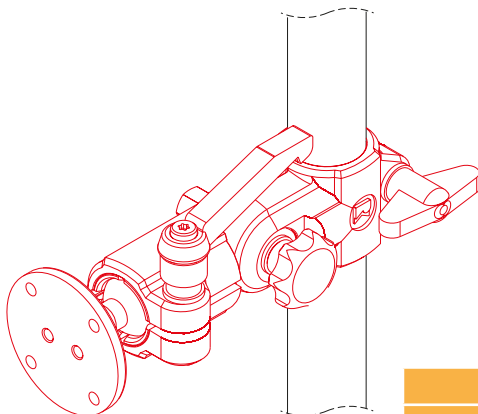
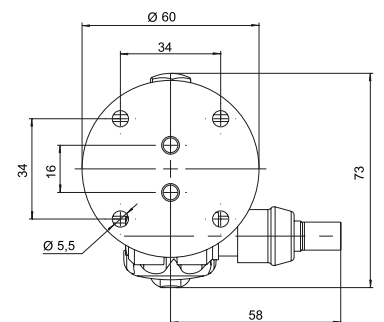
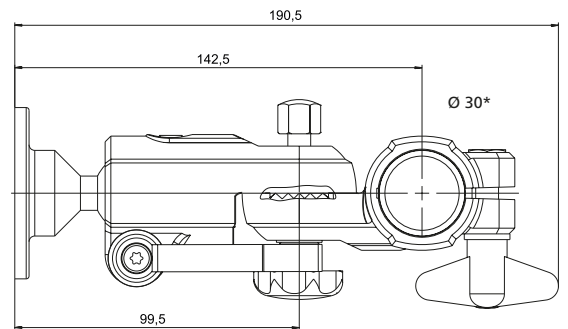

60°

Code No.	Weight	max. load
193000042C11	342 g	10 kg

*Other cross-sections by reducing bushes (see page 6)

RK Monitor Mounting

Adaptor plate VESA 75/100

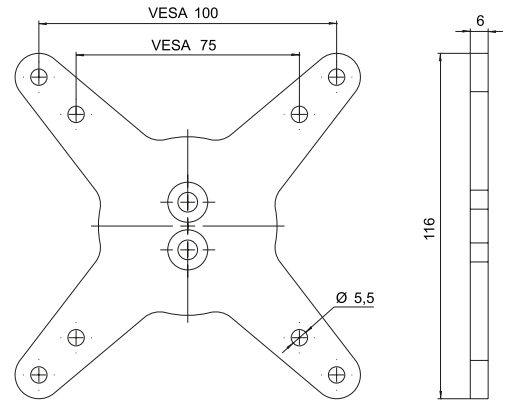
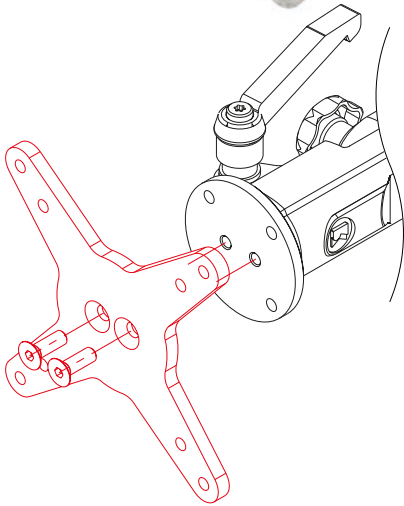

Code No.	Weight
94370	115 g





Wall console

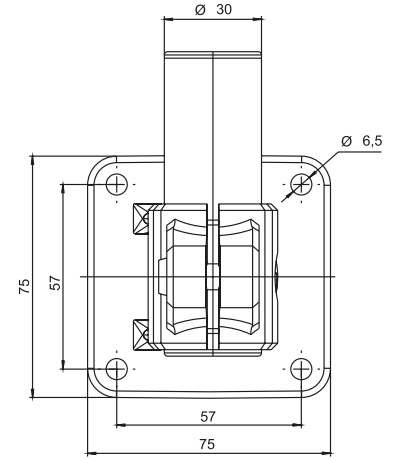
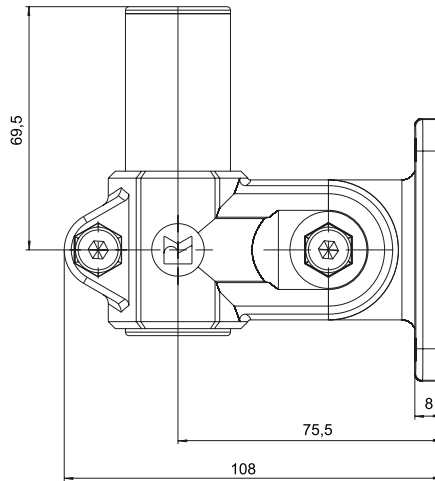
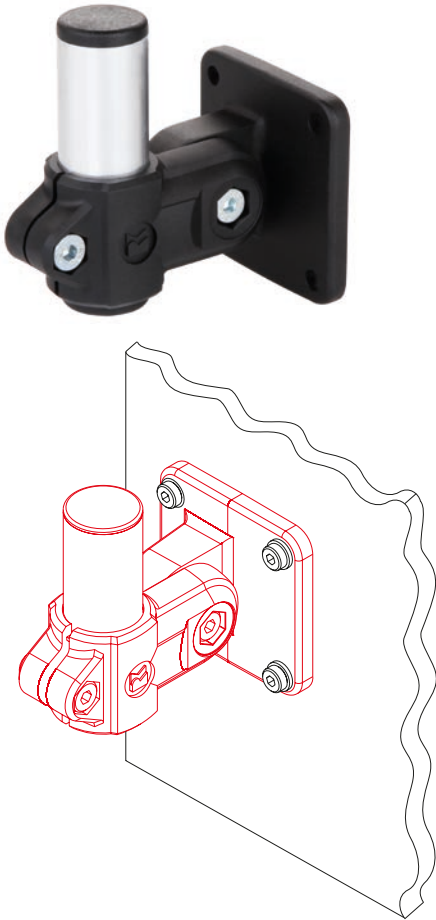

Code No.	Weight
193000358C66	306 g

Profile console

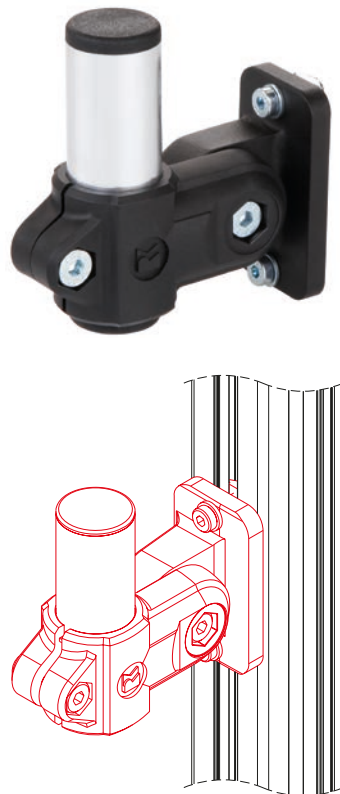

Includes:
Complete with fixing set for slot geometry 40

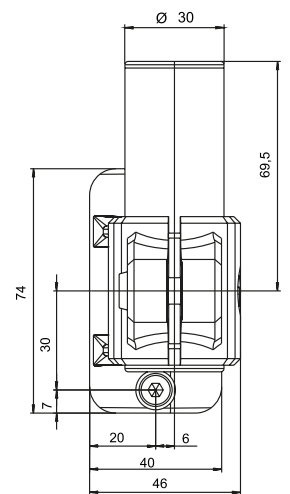
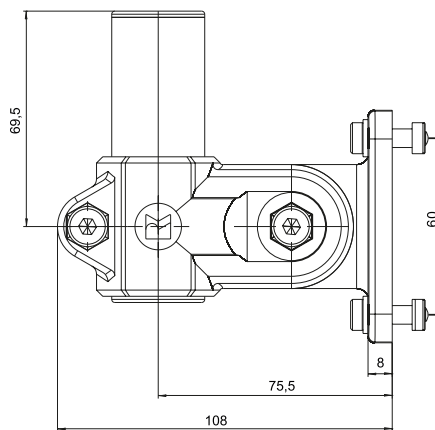

Code No.	Weight
193000298C66	270 g



Support arm double

Includes:

Complete with fixing set for slot geometry 40

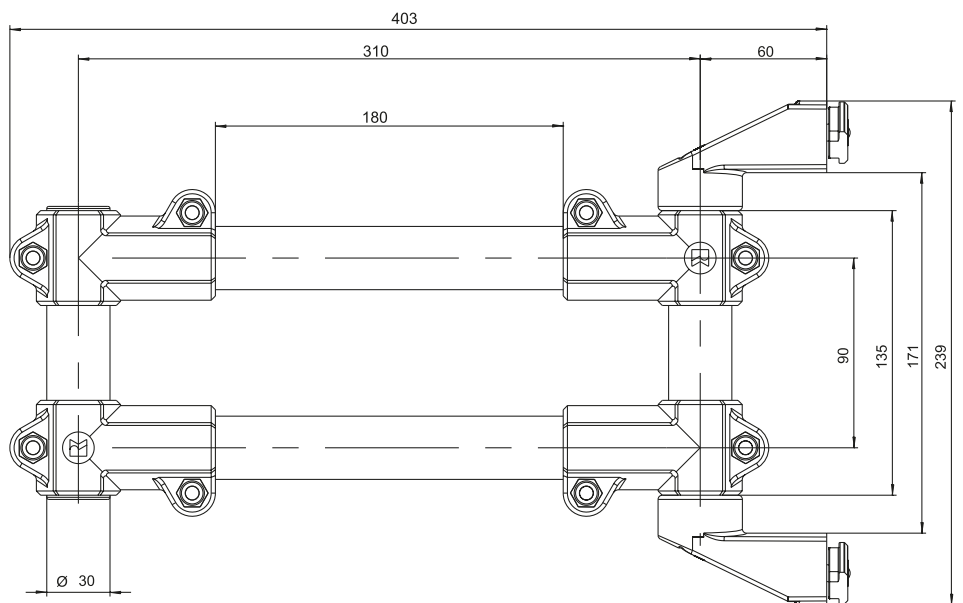
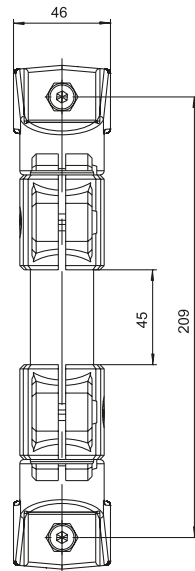
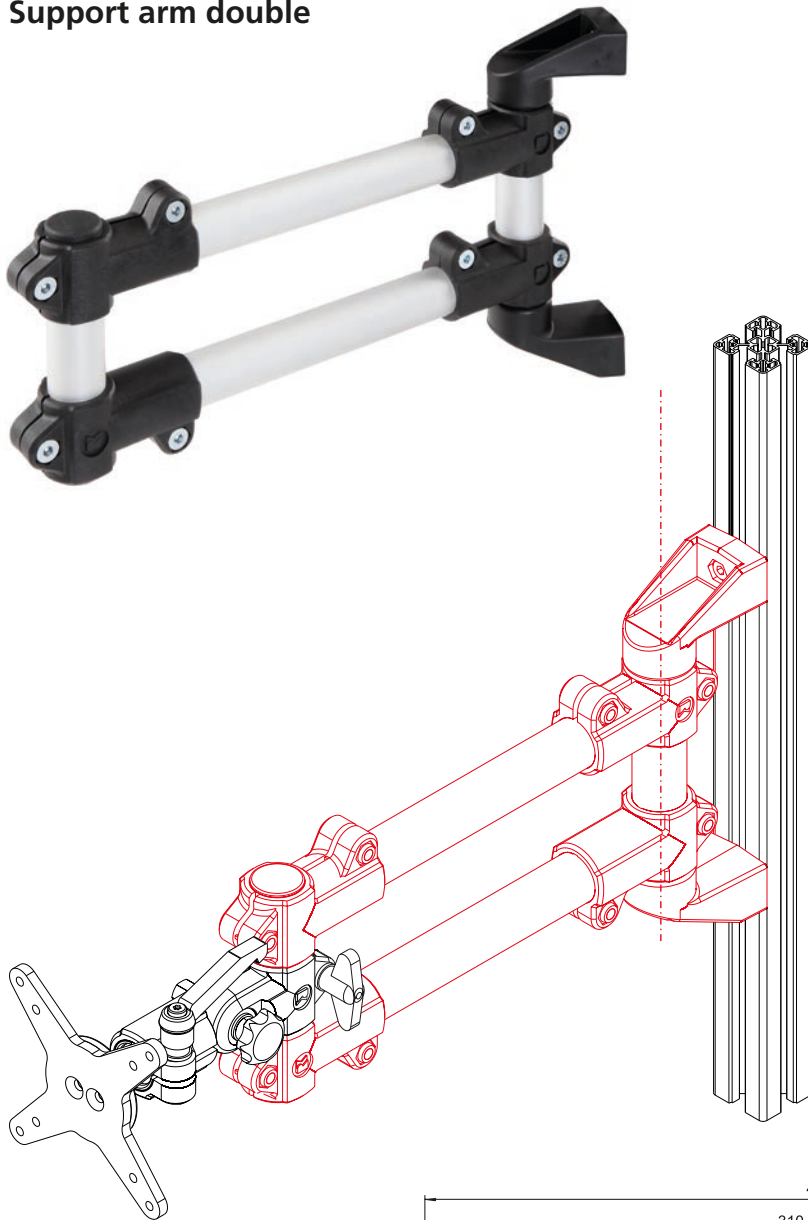

Code No.	Weight	max. load
193000028C66	1030 g	25 kg

RK Monitor Mounting

Keyboard tray

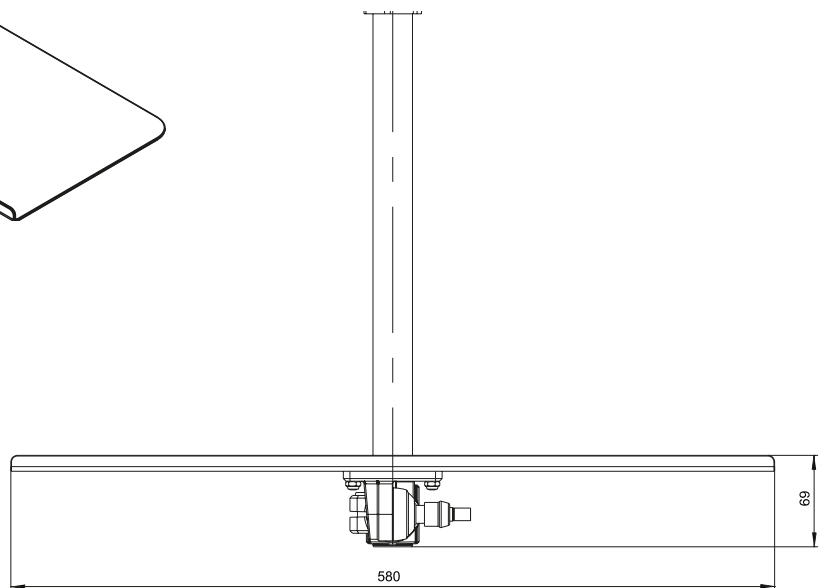
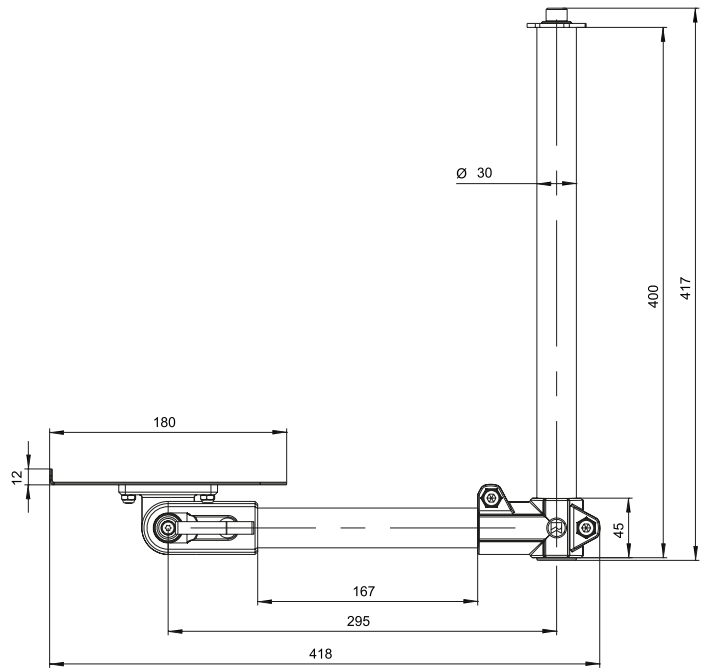
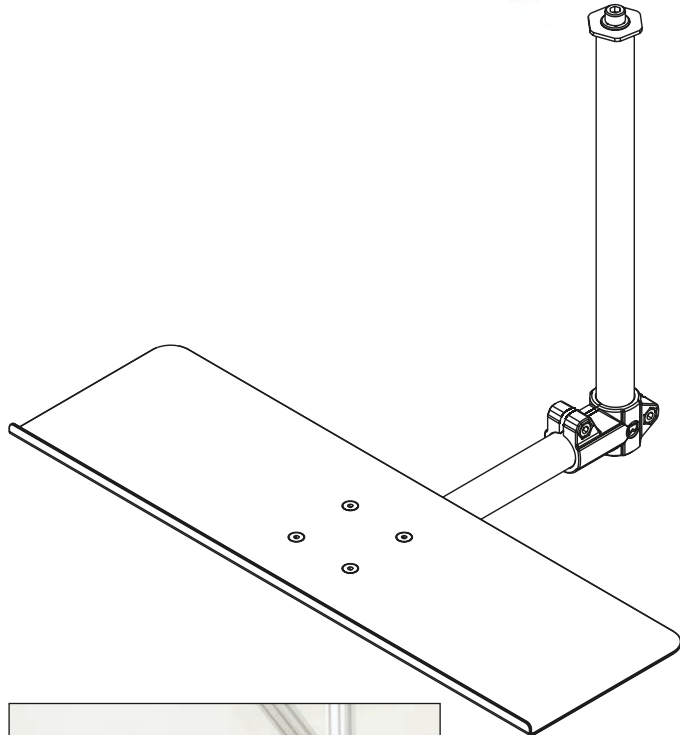

Designed for Support arm double

Code No.	Weight
193000038C66	2500 g



Tablet holder

Includes: fixing set for RK monitor mounting

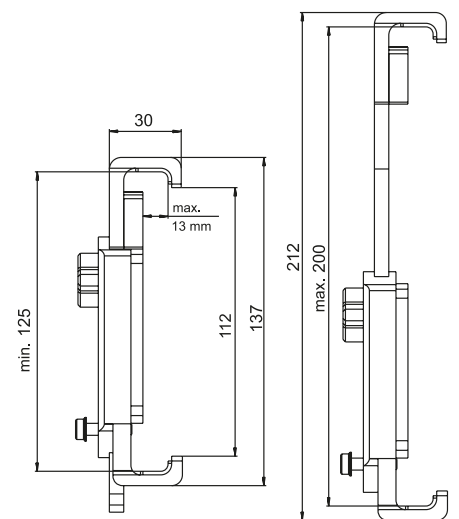
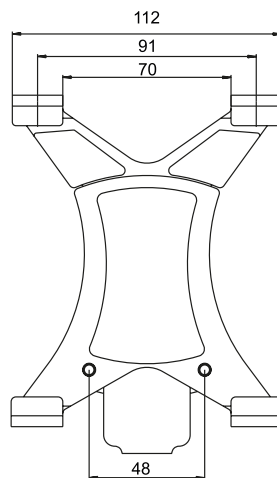
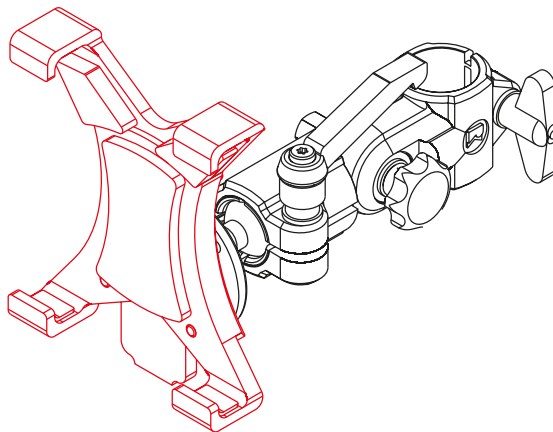
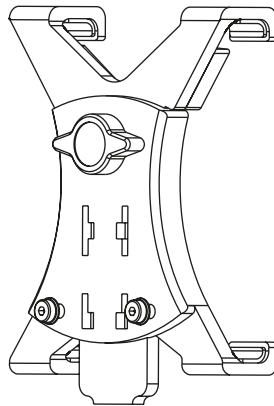

Code No.	adjustment range
193000052C66	125 mm - 200 mm

RK Monitor Mounting

Order instruction:

- Purchase only in lot sizes and a multiple of that, see product table below

Cable straps with velcro

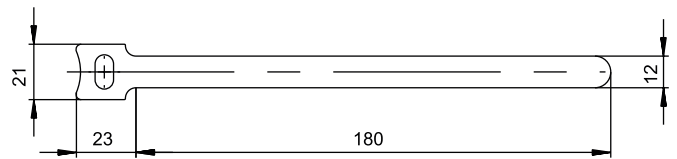

Code No.	lot sizes
91815	5, 10, 15... pcs

Clamping lever



- The clamping lever enables the re-adjustment of the clamping element. This can be done by easy exchange of the cylinder screw.
- By lifting the grip, the free movement of the serration toothing enables the clamping lever to swing into the desired position. The grip moves into its original position when released.

Material: Grip made of polyamide black, screws -stainless steel

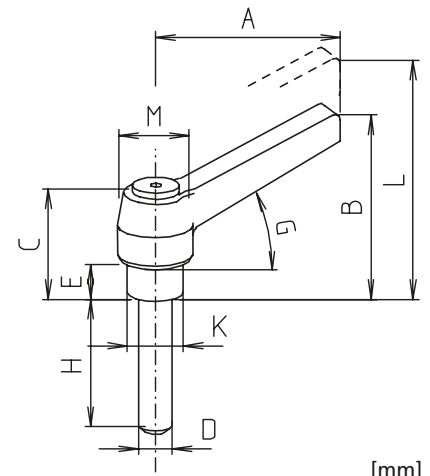
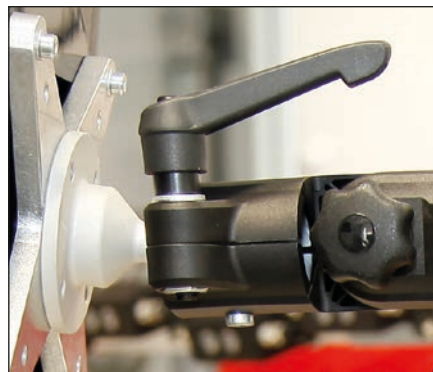

[mm]

Code No.	Type	A	B	C	D	E	G	H	K	L	M
93024	12-18	40	35,5	30	M6	10	20°	18	10	39,5	13

Order instruction:

- Purchase only in lot sizes and a multiple of that, see product table below

Reducing bushes for monitor mounting

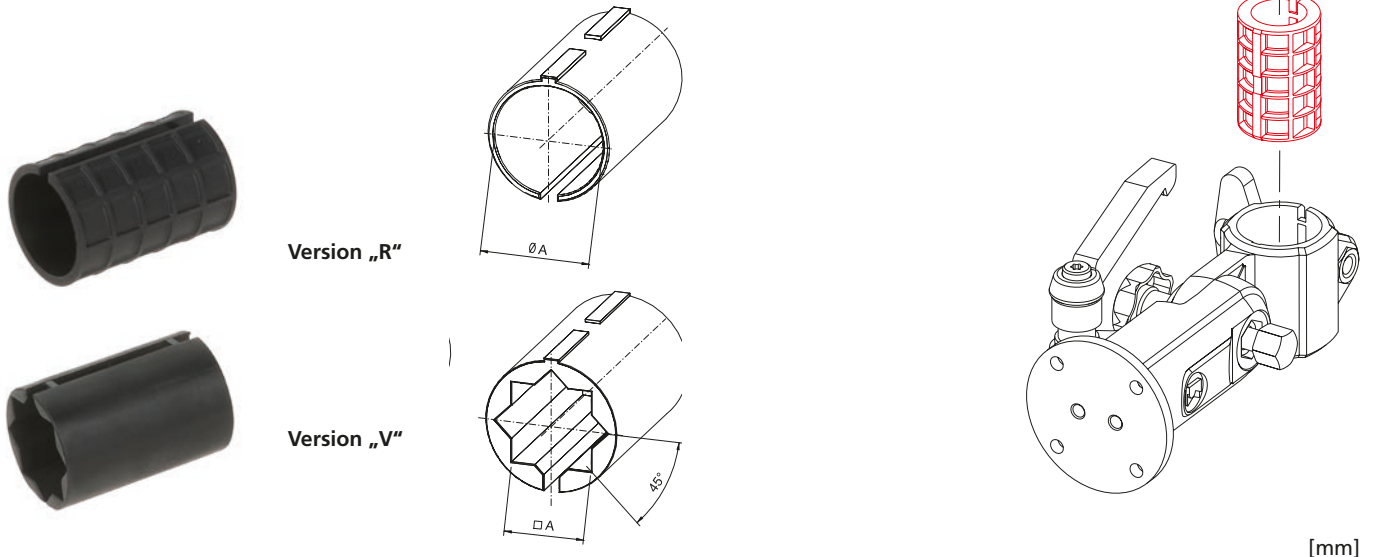

[mm]

Code No.	Version	lot sizes	A + 0,1
96204BC	R20	5, 10, 15... pcs	20,25
96206BC	R25	5, 10, 15... pcs	25,25
96208BC	V20	5, 10, 15... pcs	20,25

Vario-Quick holding block K/KK

- For fixing cables and hoses
- It is possible to insert it into the profile slot retrospectively

Material: Black plastic

Version K

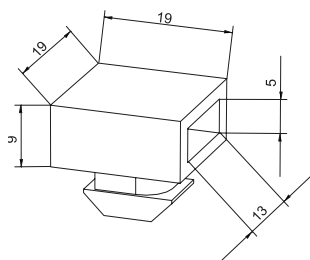

Version KK

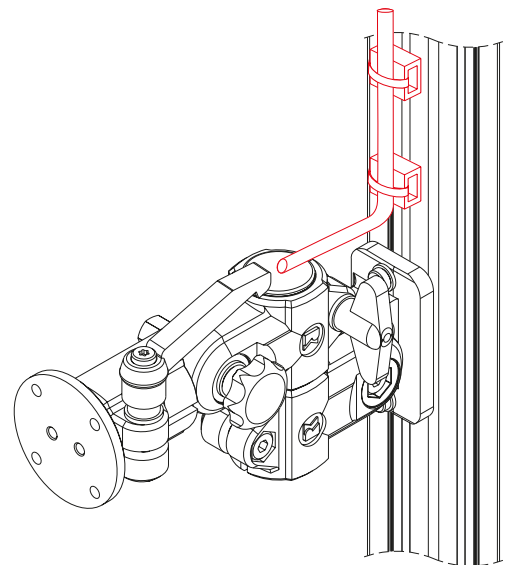
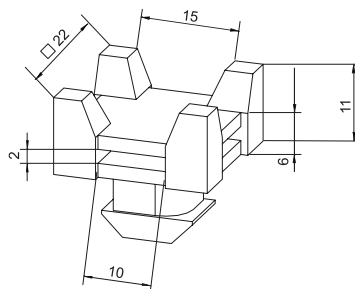

Code No.	Version	lot sizes	Suitable for
4018125	Holding block K	10, 20, 30... pcs	40 slot geometry*
4018127	Holding block KK	10, 20, 30... pcs	40 slot geometry*

* Slot geometry RK Profile Technology

Supports arm/equipment carrier system GT 48



GT AG



GT F / GT FD



GT WGW / WGS



GT AF



GT W



GT KU / GT KUF



GT WKU / WKUF



GT PF



GT NA

Features:

- Based on a standardized round steel tube 48 mm in diameter, the different system elements can be combined so as to allow individual system structures to be set up within a short time.
- The length of the steel tubes can be adjusted freely; attachment to the system elements is made with self-tapping Allen screws.

Options:

- A free cable passage 40 mm in diameter is provided.

Support arm/equipment carrier system GT Ø48 – table of contents

<p>Properties/performance data</p>	<ul style="list-style-type: none"> ■ Technical data p. 266 ■ Examples for system constructions p. 267
<p>Versions (Dimensions, code numbers)</p>	<ul style="list-style-type: none"> ■ GT AG / GT F / GT FD p. 268 ■ GT WGW / GT WGS / GT AF p. 269 ■ GT W / GT KU / GT KUF p. 270 ■ GT WKU / GT WKUF / GT PF p. 271
<p>Accessories</p> <p style="text-align: right;">Fastening</p>	<ul style="list-style-type: none"> ■ Inclining adaptor GT NA p. 272 ■ Connecting tubes Ø48 p. 272

Supports arm/equipment carrier system GT 48

Basic information / operating conditions

Surface	standard version in transport grey, RAL7043 powder-coated, other colours upon request
Tube Ø 48	zinc plated steel tube, 48x4, DIN EN 10305
Free cable passage	through fittings and tube 40 mm in diameter
Torque of tube clamp	30 Nm
Protection mode	IP 54 according to DIN 40050 (Foot stand IP 42)

Load diagram

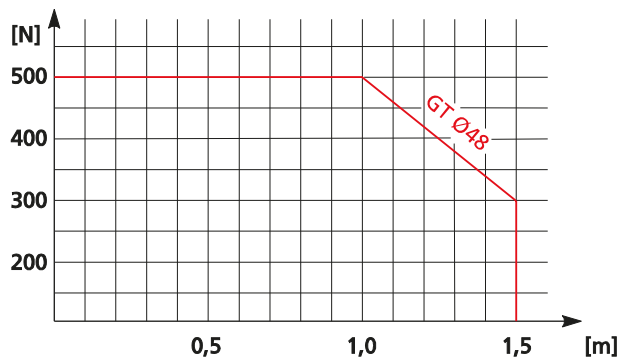

Examples for constructions:



Supports arm/equipment carrier system GT 48

Surface-mounted joint

- Cast aluminium with inner steel tube and flange fastening
- Swing 250°.



GT AG

Code No.	Type	m [g]
194800260G	GT AG 48	2000

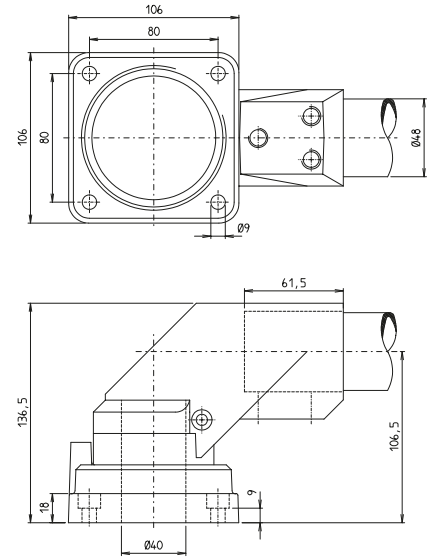

Foot stand:

- Cast aluminium



GT F

Code No.	Type	m [g]
194800240G	GT F 48	722

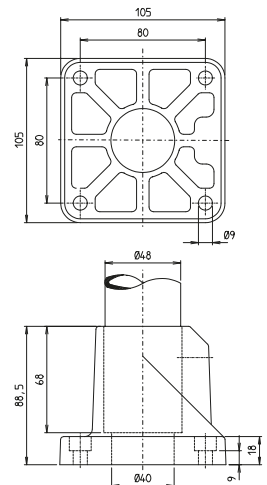

Foot stand, pivoted

- Cast aluminium with inner steel tube and slide bearing.
- Swing 250°.



GT FD

Code No.	Type	m [g]
194800340G	GT FD 48	1787

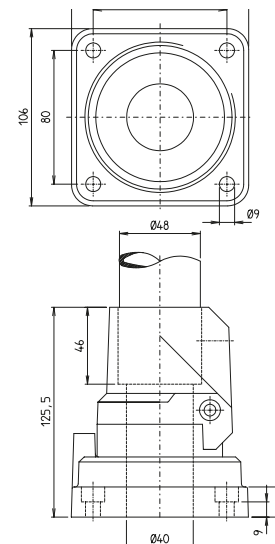

Wall hinge (horizontal)

- Cast aluminium with inner steel tube and slide bearing.
- Swing 250°

GT WGW

Code No.	Type	m [g]
194800270G	GT WGW 48	2851

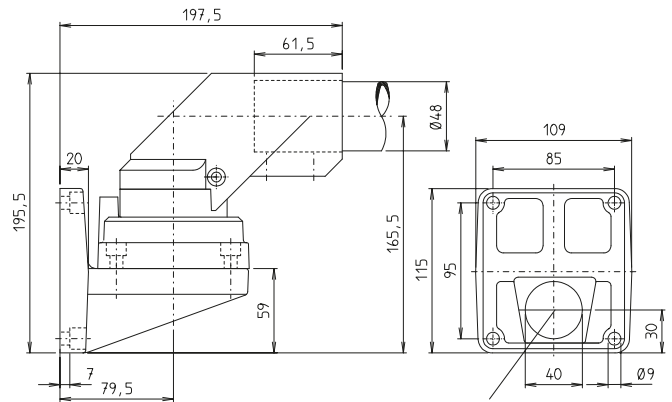

Kabeldurchführung

Wall hinge (vertical):

- Cast aluminium with inner steel tube and slide bearing.
- Swing 250°

GT WGS

Code No.	Type	m [g]
194800310G	GT WGS 48	2627

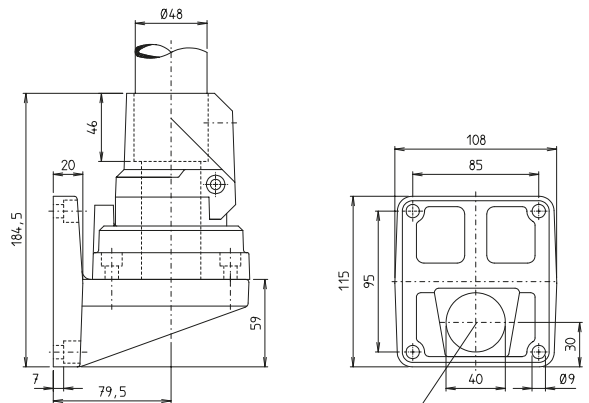

Kabeldurchführung

Adaptor flange:

- Cast steel, in combination with wall hinges as a cable lead-in, from bottom or top

GT AF

Code No.	Type	m [g]
194800111G	GT AF 48	2038

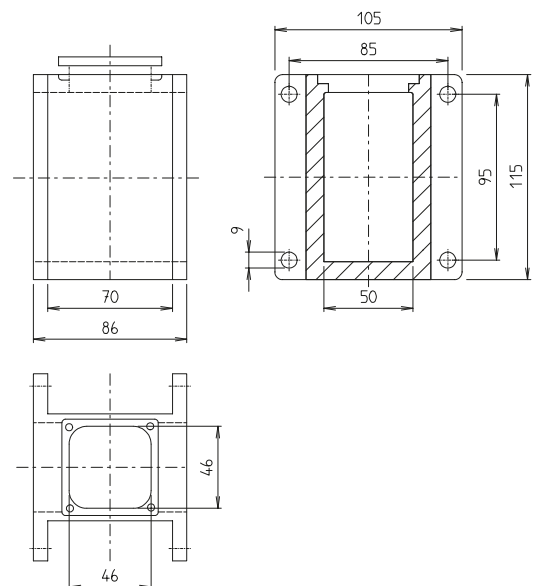

Supports arm/equipment carrier system GT 48

Elbow:

- Cast aluminium, angle 90°

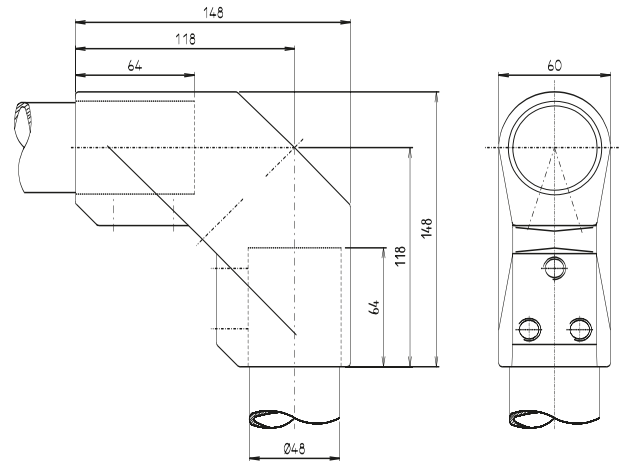

GT W

Code No.	Type	m [g]
194800280G	GT W 48	835

Coupling:

- Cast aluminium with inner steel tube
- Centre of motion infinitely variable using clamping lever
- Fitting through enclosure hole.
- Swing 260°

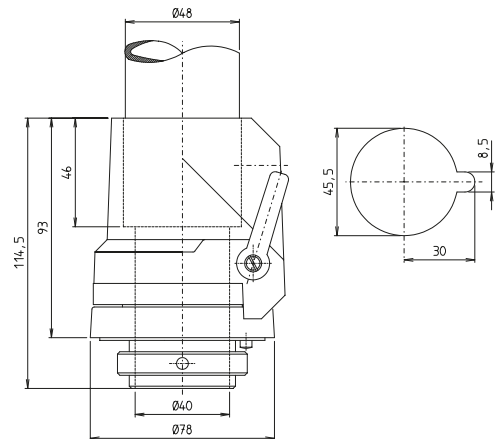

GT KU

Code No.	Type	m [g]
194800320G	GT KU 48	926

Flange coupling:

- Cast aluminium with inner steel tube
- Centre of motion infinitely variable using clamping lever
- Large-surface flange fastening on enclosure
- Swing 260°

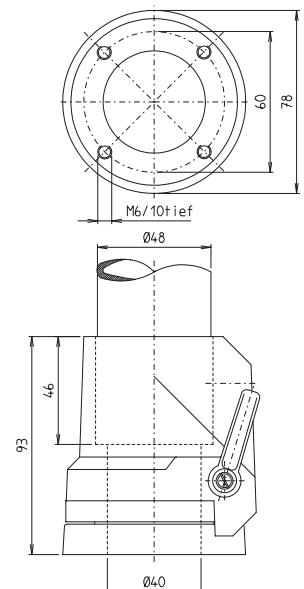

GT KUF

Code No.	Type	m [g]
194800330G	GT KUF 48	814

GT 48
Elbow coupling:

- Combination of coupling and elbow
- Fitting through enclosure hole
- Centre of motion infinitely variable using clamping lever
- Swing 260°

GT WKU

Code No.	Type	m [g]
194800290G	GT WKU 48	1140

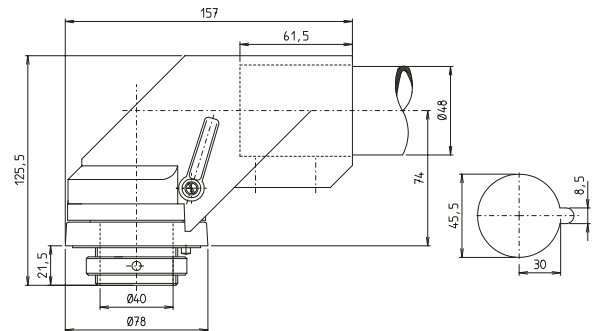
Elbow flange coupling:

- Combination of coupling and angle piece
- Large-surface flange fastening on enclosure
- Centre of motion infinitely variable using clamping lever
- Swing 260°

GT WKUF

Code No.	Type	m [g]
194800300G	GT WKUF 48	1041

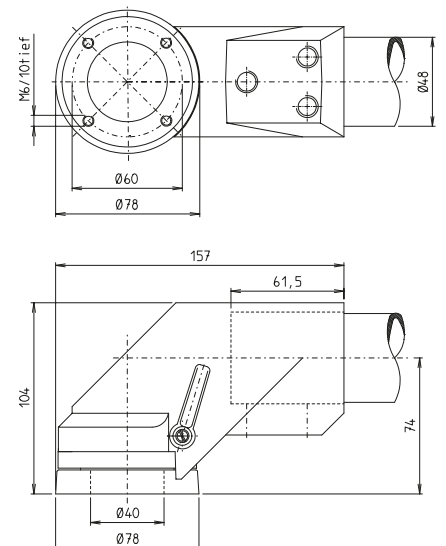
Console flange:

- Cast aluminium
- Screw fastening to coupling
- Slope angle 30°

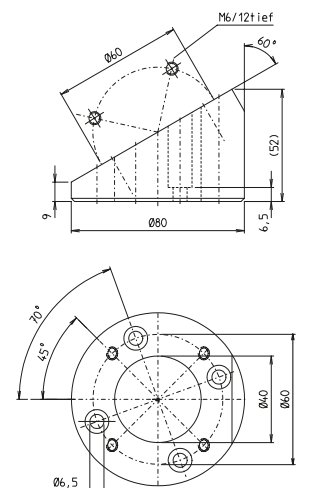

GT PF

Code No.	Type	m [g]
194800170G	GT PF 48	303

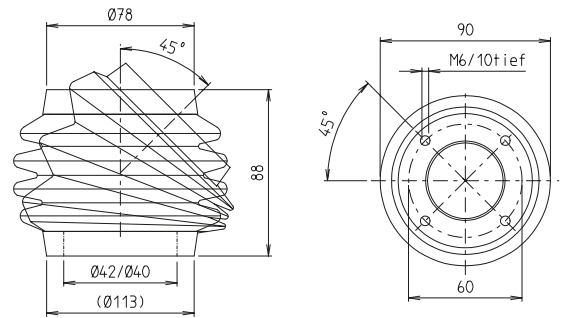

Supports arm/equipment carrier system GT 48

Inclining adaptor



GT NA

Code No.	Type	m [g]
194800250G	GT NA 48	600

Connecting tube

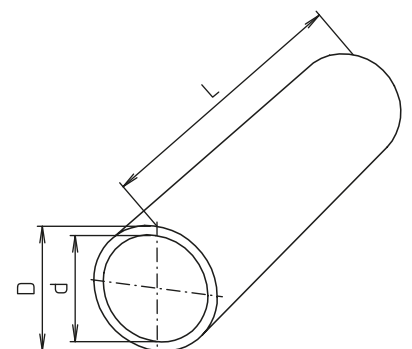

Ø48

[mm]

Code No.	Type	D tol.	d	L max.	m [g]
10094158	48x4	48 ± 0,2	40	3000	4300



Length:
Every length is possible.



Supports arm/equipment carrier system – GT 50, 60, 80



GT AG



GT F



GT WG



GT AF



GT ZG



GT W



GT WКУ



GT WКУF



GT КУ / GT КУF



GT PKU



GT PA



GT A

Features:

- Variable constructions, consisting of series produced elements, for individual attachment and positioning of control panels. Designed in clear lines the carrier system harmoniously fits in with the modern working environments.
- Free system construction using high-solid functional elements and tubular steel 50x50, 60x60, and 80x80 mm.
- Consistent IP 65 ingress protection up to the control panel is achieved by means of a self-contained tube system with integrated seals in places where the system elements are joined
- Installed cables are protected from damage due to burr-free inner contours, an unrestricted cable passage of 49 cm², and flush joints between tube and system elements
- Swing can be adjusted to on-site requirements using adjustable fittings in the rotary and swivel elements
- Easy alignment of carrier arm using pre-formed tube supports in the elements. Adjusting screws freely accessible without having to remove the bellows
- Adjustment of swing forces to different loads using infinitely variable pivot bearings

GT 50, 60, 80 – Technical data

Basic information / operating conditions

Surface	standard version in transport grey, RAL7043 powder-coated, other colours upon request
tube Ø 48	zinc plated steel tube, DIN 2395
Free cable passage	□ 50 = 40x40 mm / □ 60 = 50x50 mm / □ 80 = 70x70 mm
For tube clamping	30 Nm
Protection mode	IP 65 according to DIN 40050

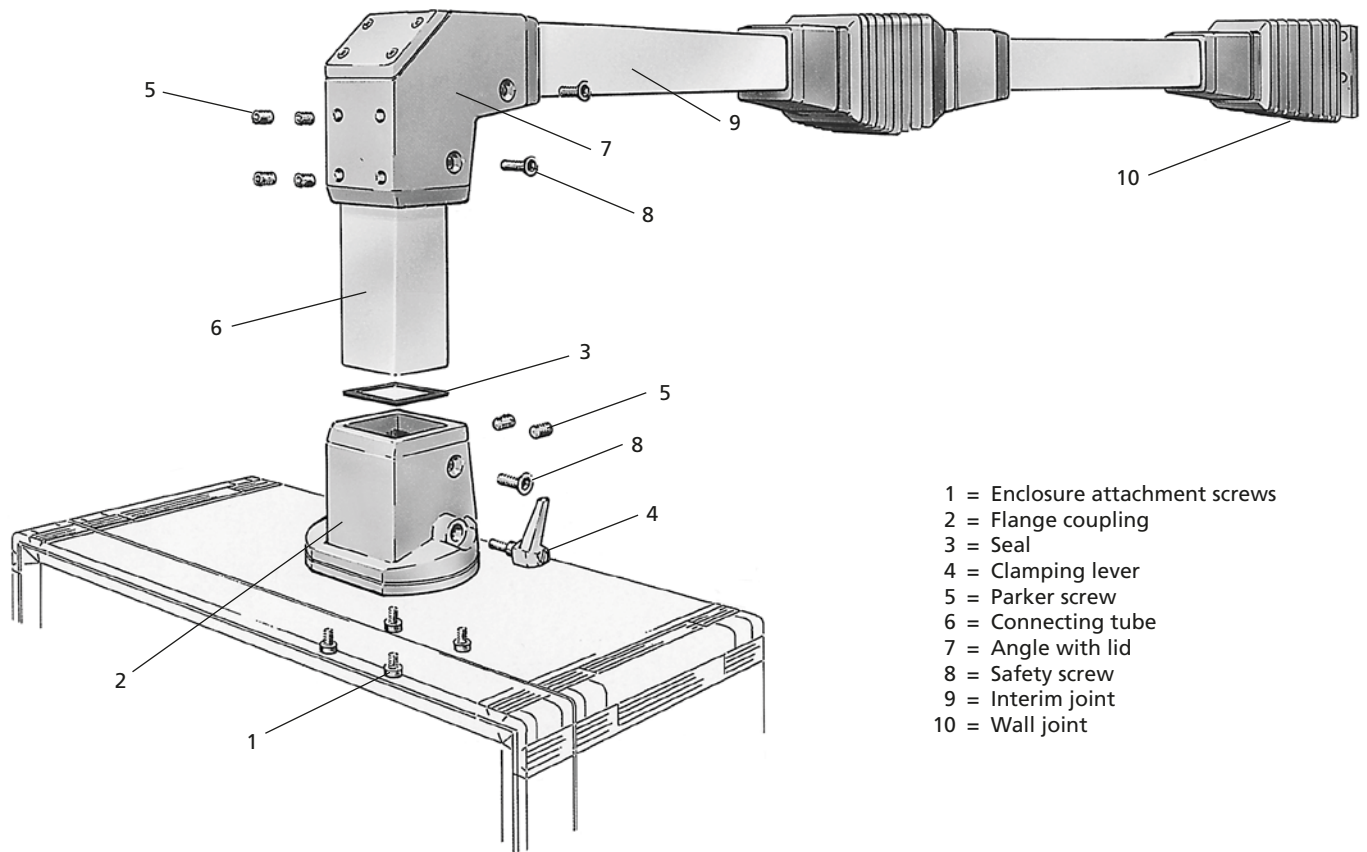

Load diagram

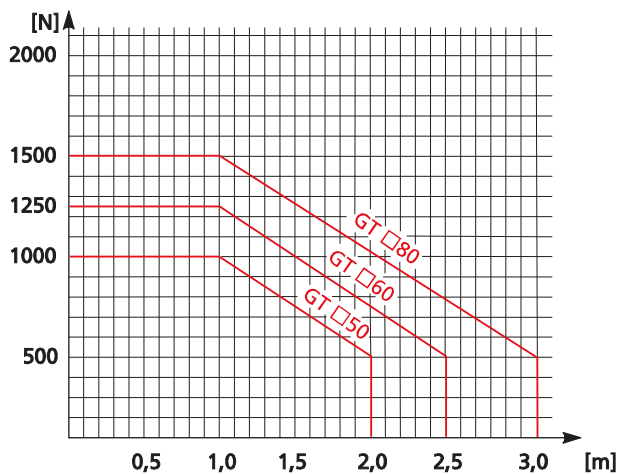

Examples for system constructions:

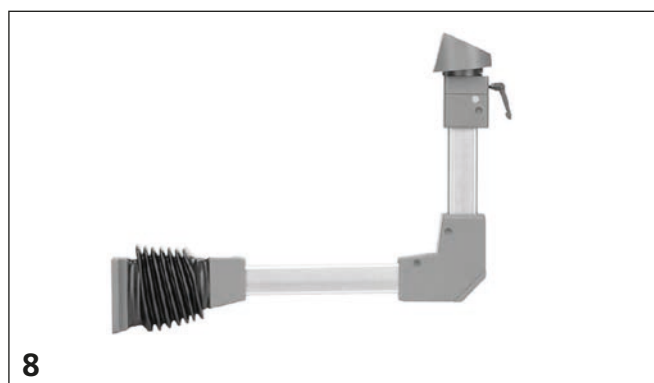
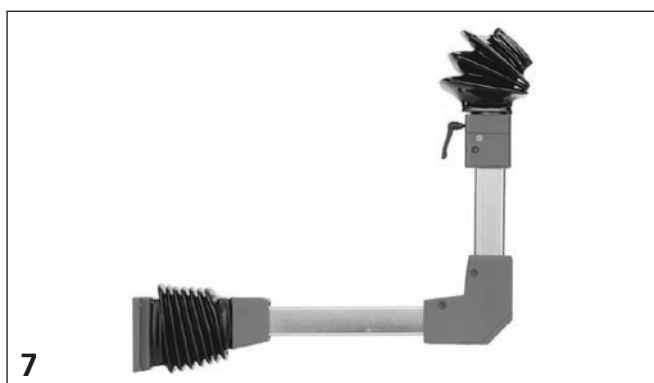
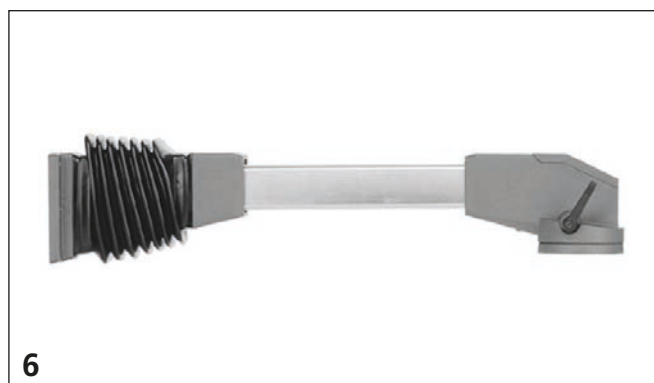
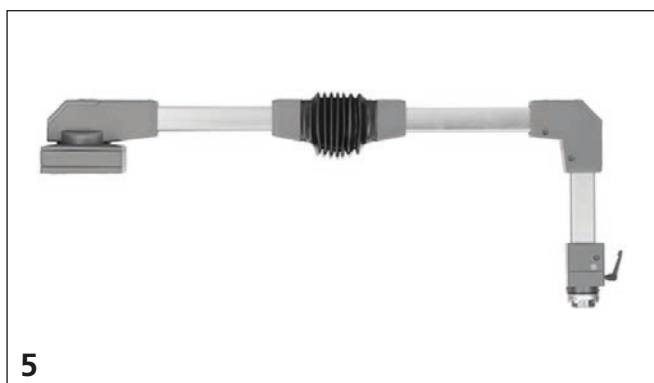
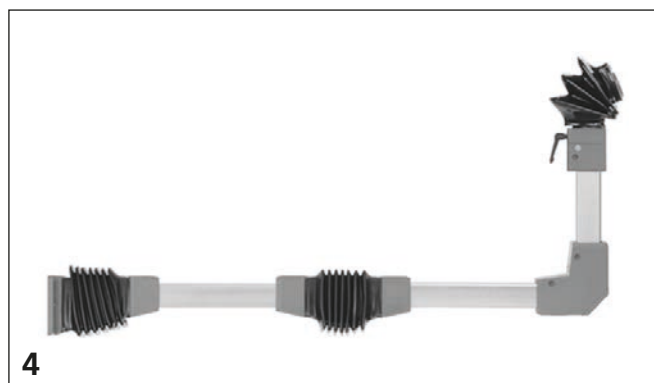
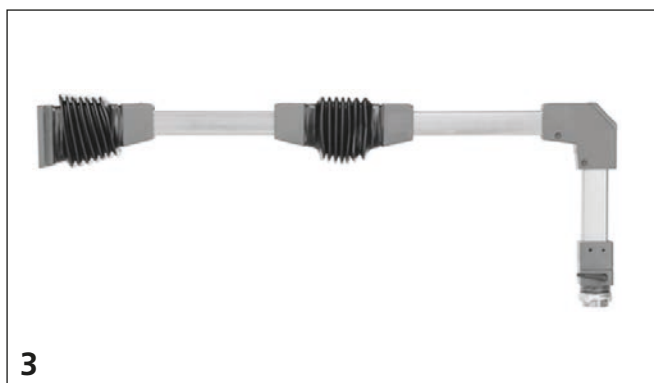
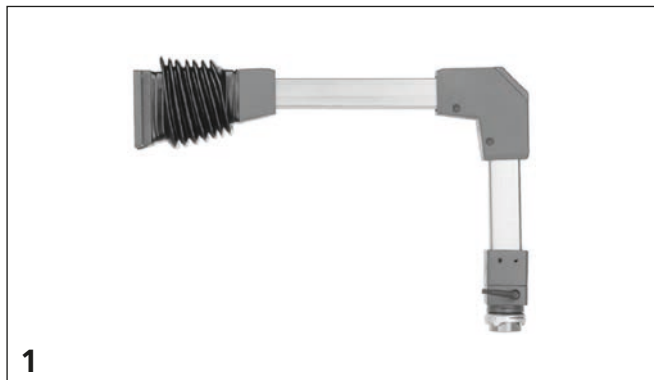

Supports arm/equipment carrier system – GT 50, 60, 80

Surface-mounted joint:

- Cast steel joint for use on mounting surfaces and for suspension mounting (ceiling mounting)
- Slide bearing with swing of 310°, infinitely variable between 0° and 270°
- Force of swing adjustable by means of a set screw. Tube clamping and alignment with self-tapping set screws
- Mounting lid to facilitate wiring

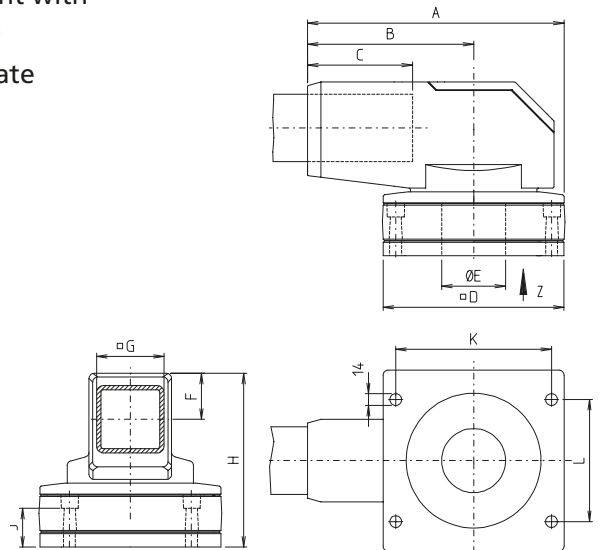

GT AG

[mm]

Code No.	Type	A	B	C	D	E	F	G	H	J	K	L	m [g]
195000261G	GT AG 50	251	160	95	180	50	39,5	50	151	35	150	116	1400
196000261G	GT AG 60	278	179,5	110	195	58	44,5	60	171	38	165	125	1820
198000261G	GT AG 80	306	197,5	125	215	76	54,5	80	206	46	185	145	2330

Foot stand:

- Cast steel element for floor mounting
- Tube clamping and alignment with self-tapping set screws

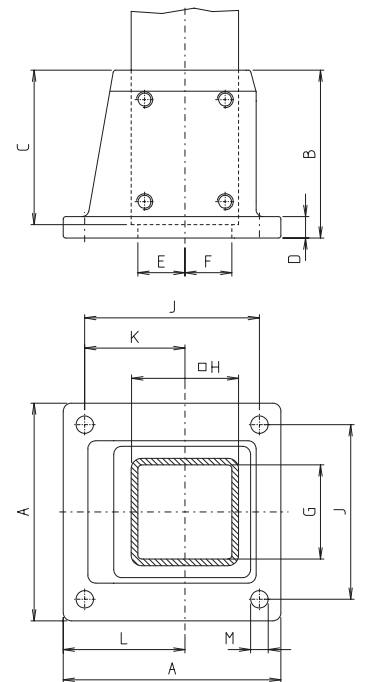

GT F

[mm]

Code No.	Type	A	B	C	D	E	F	G	H	J	K	L	M	m [g]
195000351G	GT F 50	128	90	80	12	20,5	19,5	40	50	100	57	71	12	3000
196000351G	GT F 60	138	100	90	14	25,5	24,5	50	60	110	63	77	12	3900
198000351G	GT F 80	162	115	105	16	35,5	34,5	70	80	130	74,5	90,5	14	6000

Wall hinge:

- Steel elements with slide bearing
- Swing 180°, stepped adjustment using variable fittings
- Force of swing adjustable using bearing screw. Tube clamping and alignment with selftapping set screws
- PVC bellows for dust and water protection

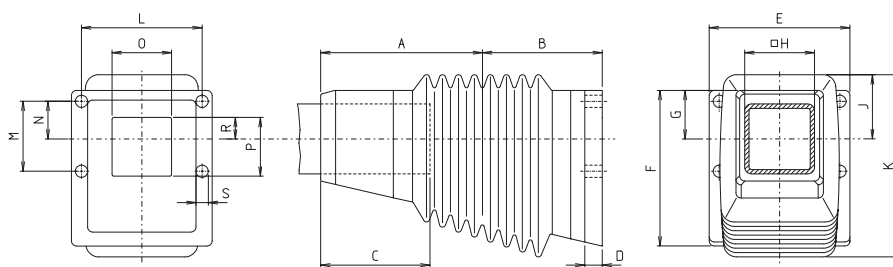
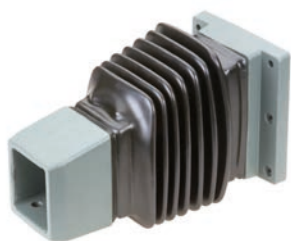

GT WG

[mm]

Code No.	Type	A	B	C	D	E	F	G	H	J	K	L	M	N	O	P	R	S	m [g]
195000271G	GTWG50	140	90	95	12	132	125	40	50	58	164	107	50	27,5	48	35	11	12	6300
196000271G	GTWG60	162	102	110	15	140	145	45	60	62	176	115	60	32,5	57	44,5	15	12	9100
198000271G	GTWG80	185	137	125	20	161	178	56	80	75	210	138	80	43,5	68	67	25	14	13000

Adaptor for wall hinge:

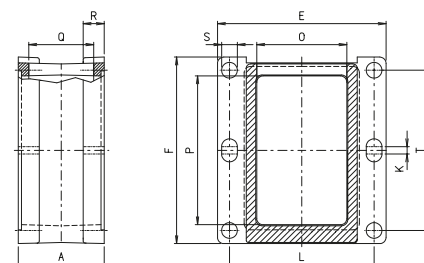
- Cast steel adaptor to be mounted between wall hinge and mounting surface
- Removable lead-in plate makes wiring possible from below.

GT AF

[mm]

Code No.	Type	A	E	F	K	L	O	S	T	P	Q	m [g]
195000111G	GT AF 50	66	132	125	0	107	107	12	100	89	46	5000
196000111G	GT AF 60	72	140	145	0	115	115	12	120	109	52	6500
198000111G	GT AF 80	82	161	178	7	138	86	15	153	142	62	6000

Supports arm/equipment carrier system – GT 50, 60, 80

Linking joint:

- Cast steel pivoted joint with slide bearing.
- Swing 180°, stepped adjustment using variable fittings.
- Force of swing adjustable using bearing screw. Tube clamping and alignment with self-tapping set screws.
- PVC bellows for dust and water protection.

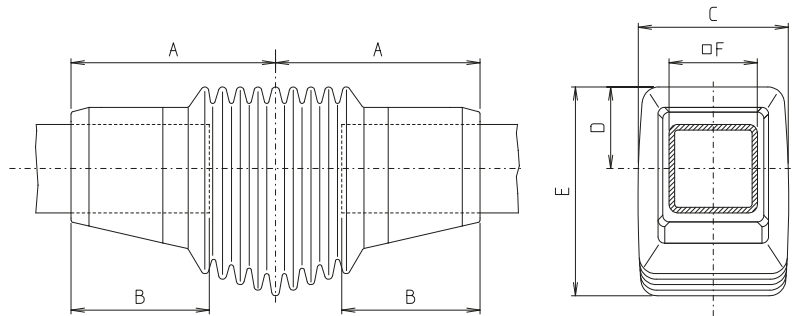

GT ZG

[mm]

Code No.	Type	A	B	C	D	E	F	m [g]
195000241G	GT ZG 50	140	95	107	58	152	50	6200
196000241G	GT ZG 60	162	110	114	62	162	60	8900
198000241G	GT ZG 80	185	125	136	75	190	80	1270

Elbow:

- Angle 90°, cast steel.
- Tube clamping and alignment with self-tapping set screws.
- Additional safety screw especially for vibration-caused strain.
- Mounting lid to facilitate wiring.

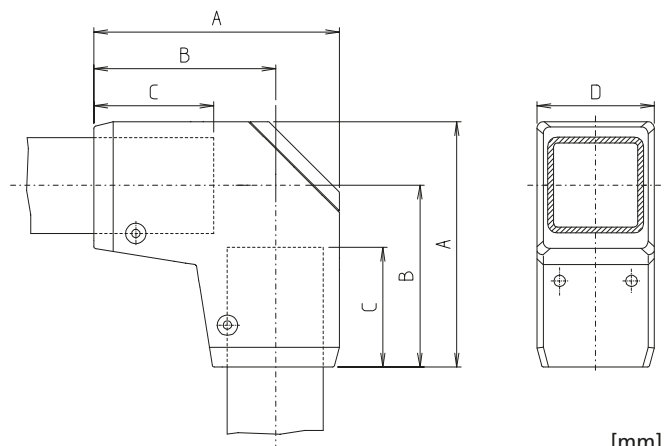

GT W

[mm]

Code No.	Type	A	B	C	D	m [g]
195000281G	GT W 50	154	115	80	74	4500
196000281G	GT W 60	172	128	90	84	5800
198000281G	GT W 80	210	157	105	98	8000

Elbow coupling:

- Combination of coupling and elbow.
- Cast aluminium.
- Fitting through enclosure hole
- Attachment to connecting tube with self-tapping set screws.
- Additional safety screw for high loads.

- Durable PA bearing. Friction force of swing adjustable. Centre of motion freely adjustable with clamping lever.
- Swing 300°.

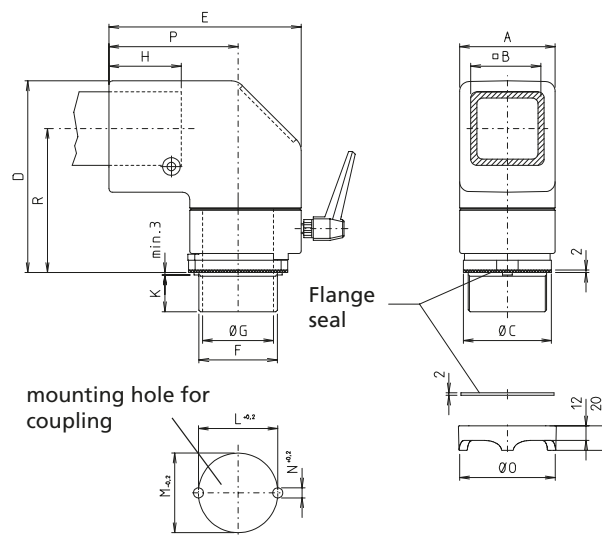
GT WKU

[mm]

Code No.	Type	A	B	C	D	E	F	G	H	K	L	M	N	O	P	R	m [g]
195000291G	GT WKU50	66	50	62	140	140	M50x2	44,5	47	31	50,8	51	8,2	65	95	104	2200
196000291G	GT WKU60	78	60	72	157	157	M64x2	56	61	31	64,8	65	8,2	80	105,5	118	3200
198000291G	GT WKU80	104	80	104	199	200	M90x2	80	72	34	90,8	91	10,2	111	137	149	5700

Elbow Flange coupling:

- Cast aluminium rotary joint for direct attachment of control-panel to horizontal carrier arm.
- Slide bearing with 325° swing, can be arrested at intervals of 25°.

- Clamping lever to adjust force of movement and to arrest swinging movement. Tube clamping with self-tapping Allen screws. Mounting lid to facilitate wiring

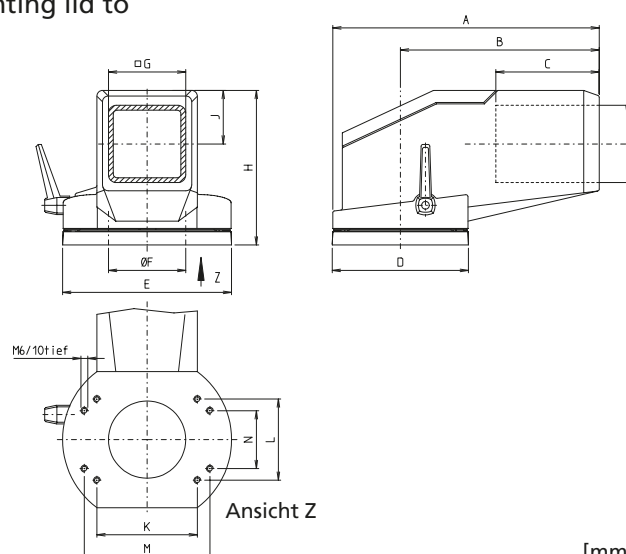
GT WKUF

[mm]

Code No.	Type	A	B	C	D	E	F	G	H	J	K	L	M	N	m [g]
195000301G	GT WKUF 50	187,5	134	80	107	131	48	50	118	39,5	77	57	-	-	2600
196000301G	GT WKUF 60	216,5	158	90	117	141	58	60	131	42,5	77	57	-	-	3600
198000301G	GT WKUF 80	276,5	206	107	141	175	80	80	160	55,5	104	84	130	60	5600

Supports arm/equipment carrier system – GT 50, 60, 80

Coupling:

- Cast aluminium with inner steel tube
- Fitting through enclosure hole. Attachment to connecting tube with self-tapping set screws.
- Additional safety screw for high loads
- Durable PA bearing.

- Friction force of swing adjustable. Centre of motion infinitely variable using clamping lever.
- Swing 300°



GT KU

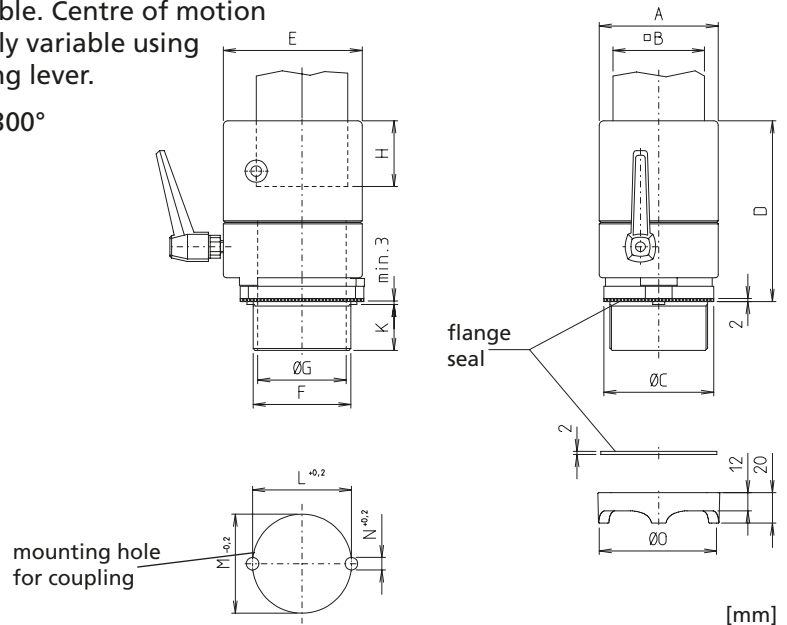

[mm]

Code No.	Type	A	B	C	D	E	F	G	H	K	L	M	N	O	m [g]
195000321G	GT KU 50	66	50	62	99,5	82	M50x2	44,5	32	31	50,8	51	8,2	65	1800
196000321G	GT KU 60	78	60	72	118,5	91	M64x2	56	45	31	64,8	65	8,2	80	2400
198000321G	GT KU 80	104	80	104	145,5	115	M90x2	80	49	34	90,8	91	10,2	111	3400

Flange coupling:

- Cast aluminium rotary device for attachment to the control panel.
- Slide bearing with 325° swing, adjustable at intervals of 25°.
- Clamping lever to adjust force of movement and to arrest swinging movement.
- Tube clamping with self-tapping set screws.

- Additional safety screw especially for vibration-caused strain.



GT KUF

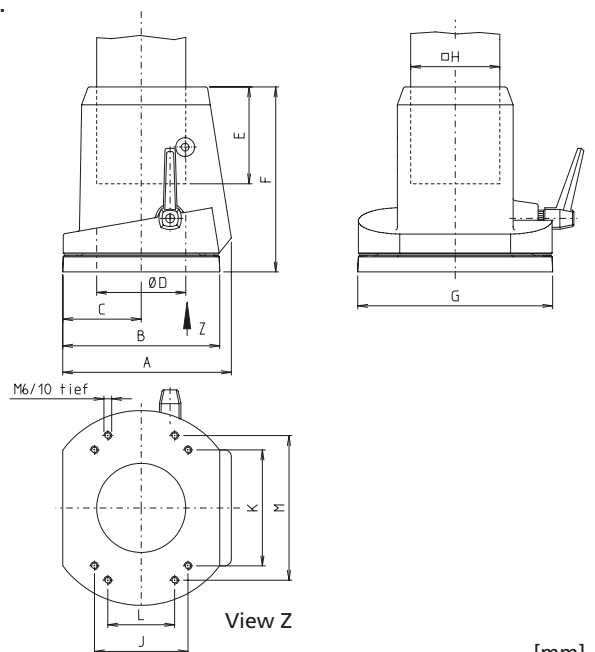

[mm]

Code No.	Type	A	B	C	D	E	F	G	H	J	K	L	M	m [g]
195000331G	GT KUF 50	110	107	53,5	48	55	116	131	50	57	77	–	–	2100
196000331G	GT KUF 60	124	117	59,5	58	65	136,5	141	60	57	77	–	–	2800
198000331G	GT KUF 80	151	141	70,5	80	87	166	175	80	84	104	60	130	4900



Console coupling:

- Cast aluminium with inner steel tube.
- Large-surface mounting on enclosure. Attachment to connecting tube with self-tapping set screws.
- Additional safety screw for high loads.
- Durable PA bearing.

- Friction force of swinging movement adjustable. Centre of motion infinitely variable using clamping lever.
- Swing 300° - angle of slope adjustable.



View Z

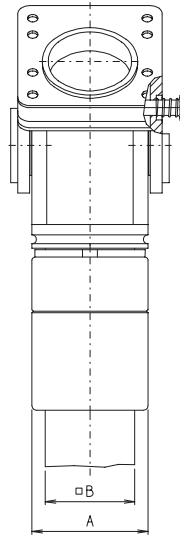

View Z

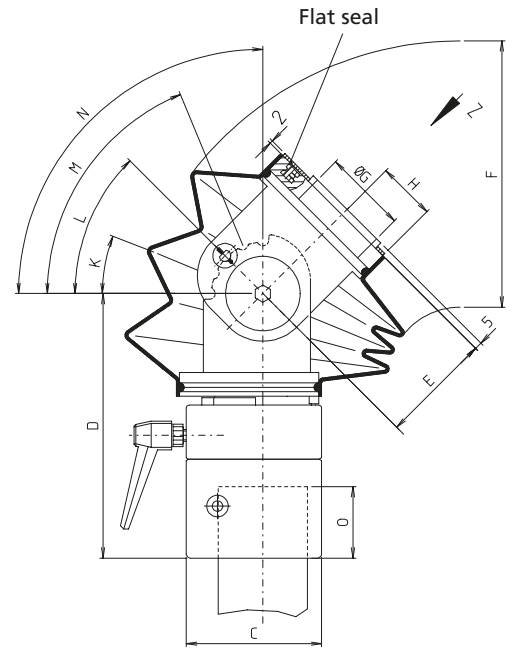

View Z

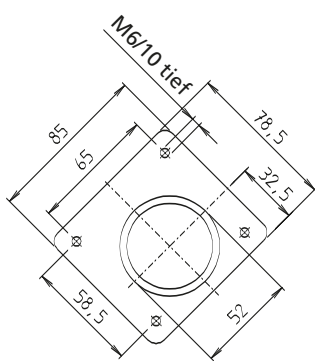

Flange dimensions GT PKU 50

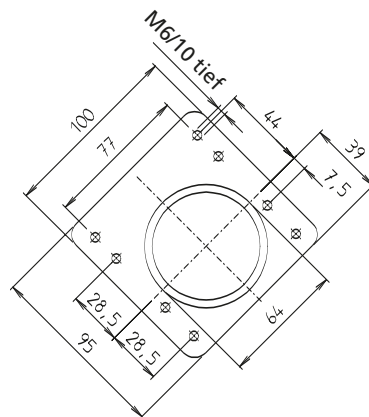

Flange dimensions GT PKU 60

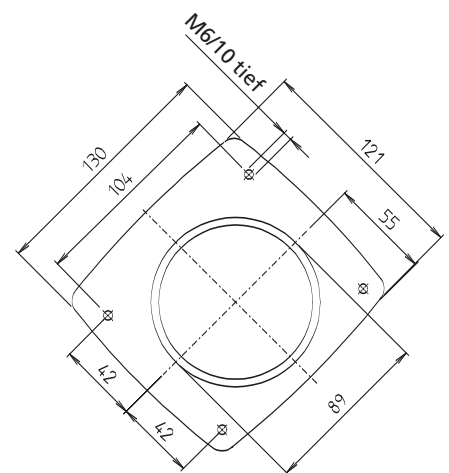

Flange dimensions GT PKU 80

GT PKU

[mm]

Code No.	Type	A	B	C	D	E	F	G	H	K	L	M	N	O	m [g]
195000250G	GT PKU 50	66	50	82	142	44	115x103	44,5	32,5	15°	32,5°	50°	-	32	1800
196000250G	GT PKU 60	78	60	91	178	75	180x160	56	39	22,5°	45°	67,5°	90°	45	2200
198000250G	GT PKU 80	104	80	115	212	84	210x180	80	55	22,5°	45°	67,5°	90°	49	2800

Supports arm/equipment carrier system – GT 50, 60, 80

Console adaptor:

- Cast aluminium
- 30°-inclination for flange coupling 50, 60, 80



GT PA

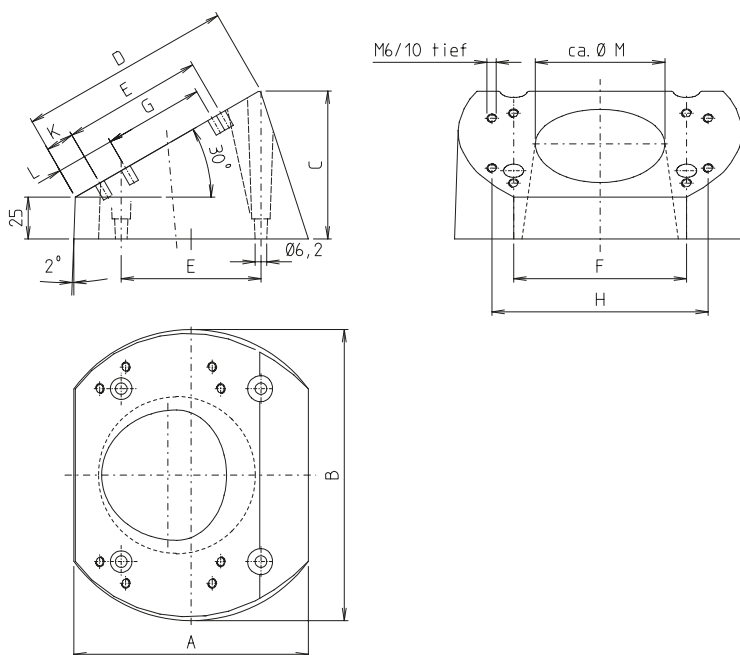

[mm]

Code No.	Type	A	B	C	D	E	F	G	H	K	L	M	m [g]
195000160G	GT PA 50	107	131	71	92	57	77	–	–	14	–	50	800
196000160G	GT PA 60	117	141	76	102	57	77	–	–	18	–	60	1000
198000160G	GT PA 80	141	175	89	128	84	104	60	130	17	35	80	1700

Signal fitting:

- Cast aluminium
- For mounting signal lamps



GT A

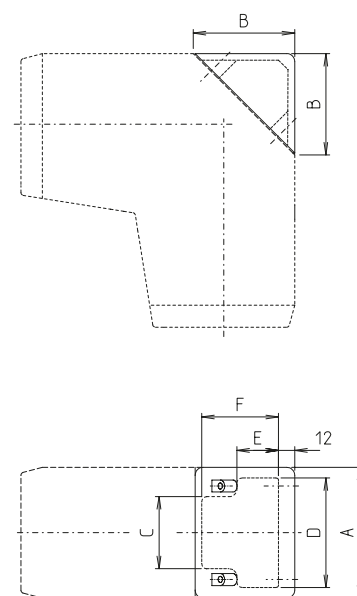

[mm]

Code No.	Type	A	B	C	D	E	F	m [g]
195000310G	GT A 50	74	60	36	54	29	38	300
196000310G	GT A 60	84	65	40	62	32	43	400
198000310G	GT A 80	98	76	54	82	42	54	600

Square Connecting tubes

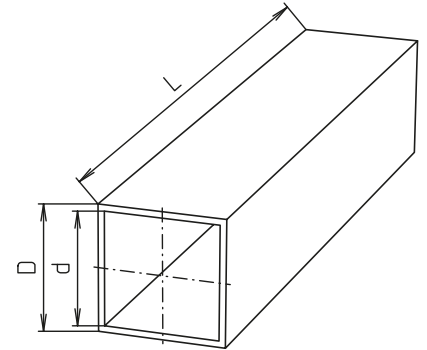

□ 50, 60, 80

[mm]

Code No.	Type	D tol.	d	L max.	m [g]
10094156_ _ _ _	50x5	50 ± 0,3	40	3000	6900/m
10094157_ _ _ _	60x5	60 ± 0,4	50	3000	8500/m
10094159	80x5	80 ± 0,6	70	3000	11600/m

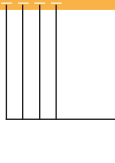

Length:
Every length is possible.

